

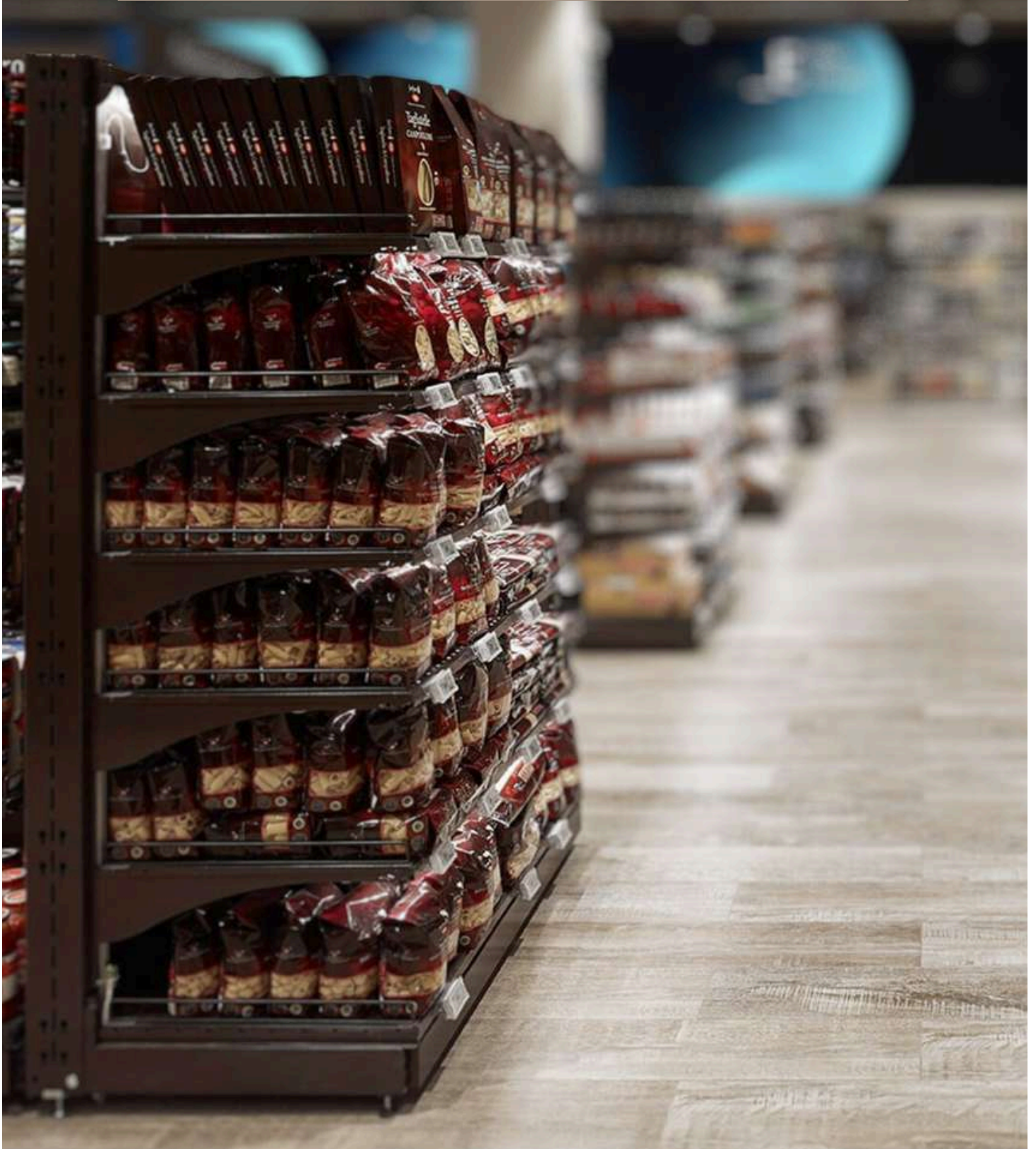

SOVA
RETAIL SOLUTIONS

**SUPERMARKET
FIXTURES & EQUIPMENT**

True Ideas for Retail Spaces



HELLO.

WE'RE **SOVA**.

WE'RE HERE TO OFFER YOU A NEW **PATH**.

WE **DREAM** RETAIL WE **DESIGN** RETAIL WE **PLAN**
RETAIL WE **KNOW** RETAIL WE **UNDERSTAND** RETAIL WE
EXPERIENCE RETAIL WE **THINK** RETAIL WE **MAKE** RETAIL
WE **ADMIRE** RETAIL

WE **LOVE** RETAIL



You can scan the QR code to access the technical catalogs.

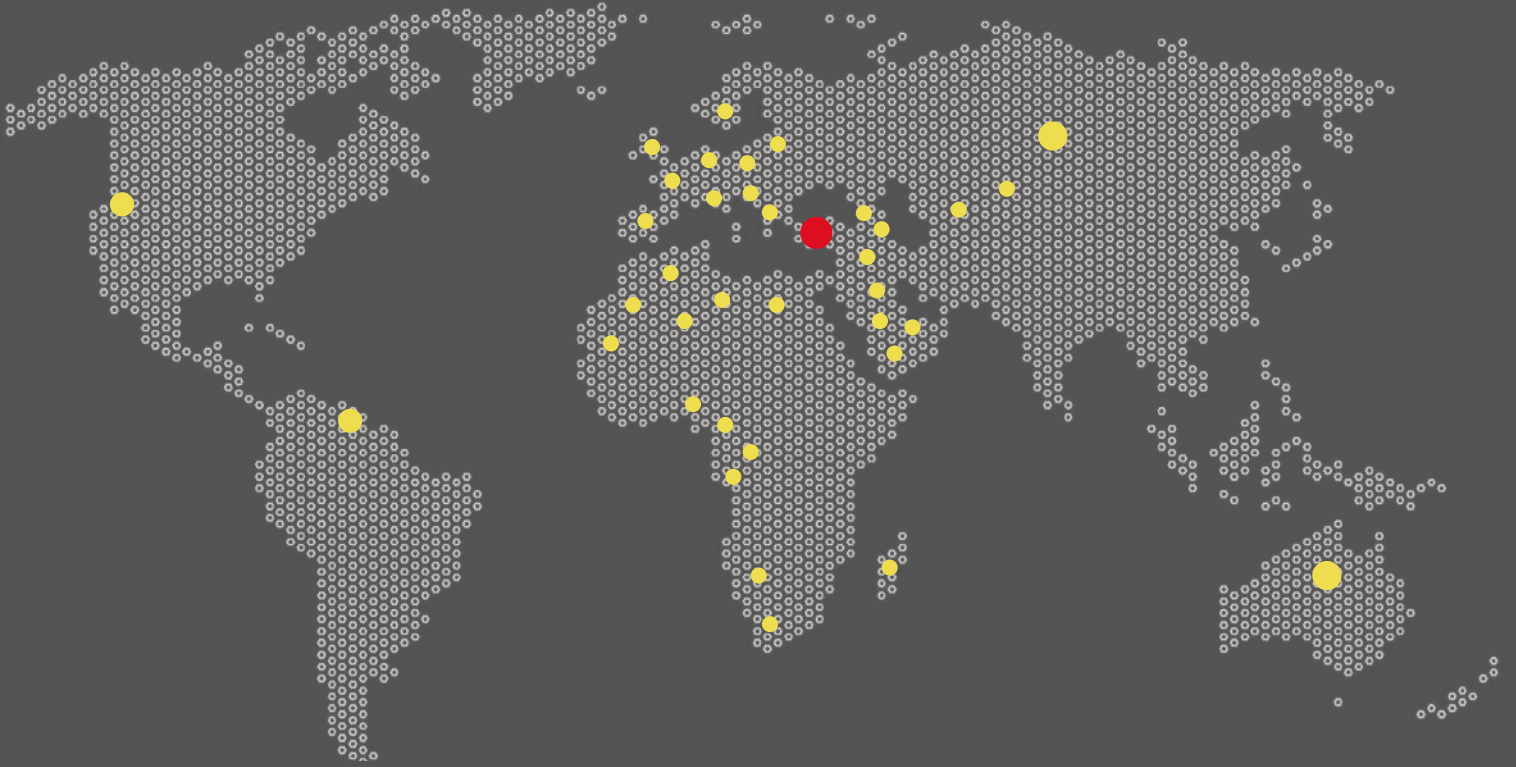

Global Reach, Worldwide Service

With robust access to diverse markets across the globe, we have the capability to execute projects in various regions. We combine quality and reliability to deliver excellence in international markets. As a trusted partner, we provide solutions to global retail chains in numerous countries worldwide.

Strong Partnerships in Local and Global Markets

With extensive experience and expertise, we have successfully completed countless projects across all provinces of Turkey and in over 30 countries worldwide. Together with our expert SOVATEAM, we are redefining retail and shaping the future of the industry.

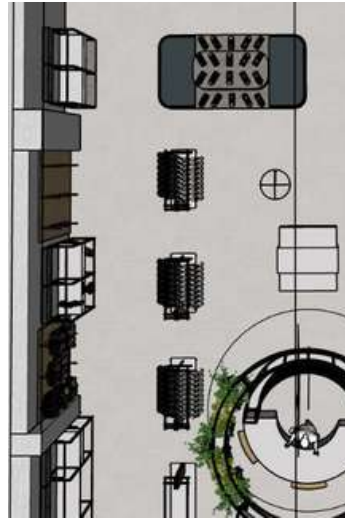
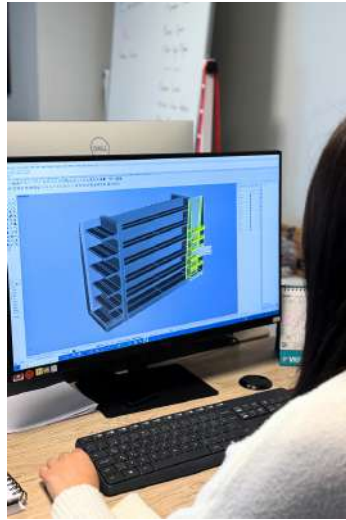

FROM PRODUCT TO SPACE

“Would you like to work with a design team that truly understands you?”

We meticulously plan and execute every step—from designing products that add value to your stores to creating the perfect spaces to showcase them.

This process, where functionality meets aesthetics, is enriched with creative solutions that highlight your products.

At every stage, we offer a unique and holistic approach tailored to the specific needs of your brand.

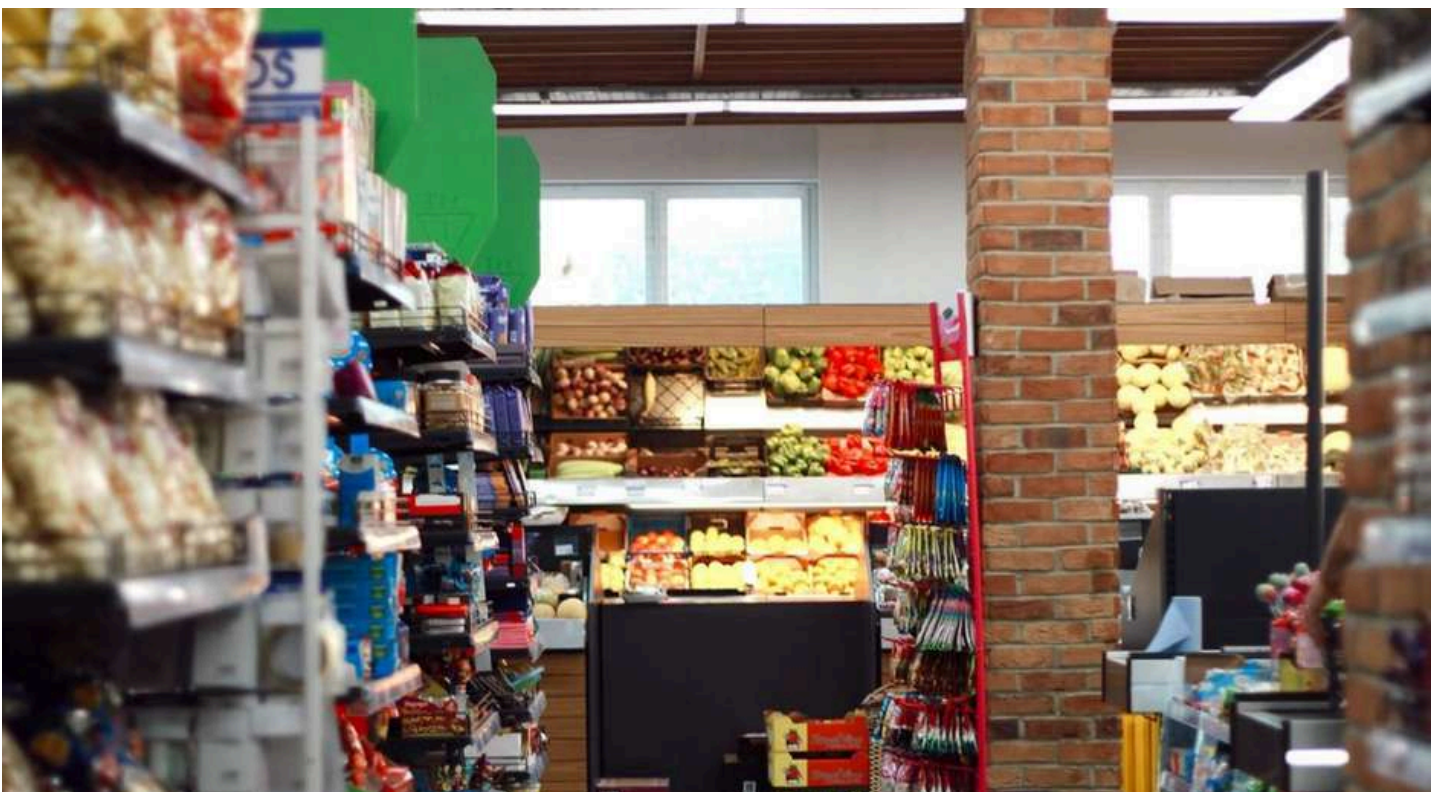

DISCOVER OUR PRODUCT RANGE AND ADD VALUE TO YOUR RETAIL BUSINESS

1-METAL SHELVING SYSTEMS	01
2-CHECKOUTS	12
3-F&V DISPLAYS	18
4-BAKERY DISPLAYS	38
5-DISPLAY STANDS	46
6-DISPLAY ACCESSORIES	58
7-SHOPPING TROLLEYS & BASKETS	60

SHELVING SYSTEMS

S25 METAL SHELVING SYSTEM



Versatile and Functional Display Solution

S25 Metal Shelving System is the most flexible shelf system, thanks to its 25 mm pitch configuration. It leaves minimal visual traces with its thin shelf front section, thus increasing the visibility of the products on display. It has a more slim overall look with its low-positioned base feet.

S25 Metal Shelving System is used with Bakery, Beverage and Dynamic! Display systems which are part of the Sova Product Ecosystem. All parts and accessories used in these systems are compatible with the S25 Metal Shelving System.

S35 METAL SHELVING SYSTEM



Maximum Flexibility and Storage Solution

S35 Metal Shelving System offers a pitch of 35 mm which is another widely used system in the world.

S35 Shelf system is used with Fruit & Vegetable Displays of the Sova Product Ecosystem. All parts and accessories used in these displays are compatible with the S35 System.

S50 METAL SHELVING SYSTEM



Optimized Display and Storage

Being a robust and strong shelving system, the S50 Metal Shelving System features a pitch of 50 mm and an easy installation.

S50 metal shelving system, is the most preferred type worldwide, and it is universally compatible with other 50 mm pitch shelving systems.

S50 TECHNICAL DETAILS

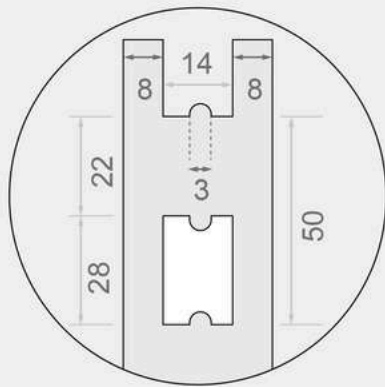

50 Pitch

POWDER COATING FEATURES

Electrostatic Epoxy Polyester Powder Paint

- | | | |
|--|--|---|
|  RAL 9010 |  RAL 3020 | Alternative color work can be done in line with the customer's request. |
|  RAL 7035 |  RAL 1023 | |
|  RAL 7016 |  RAL 5010 | |
| |  RAL 6018 | |
| |  RAL 2008 | |

UNIT DIMENSIONS

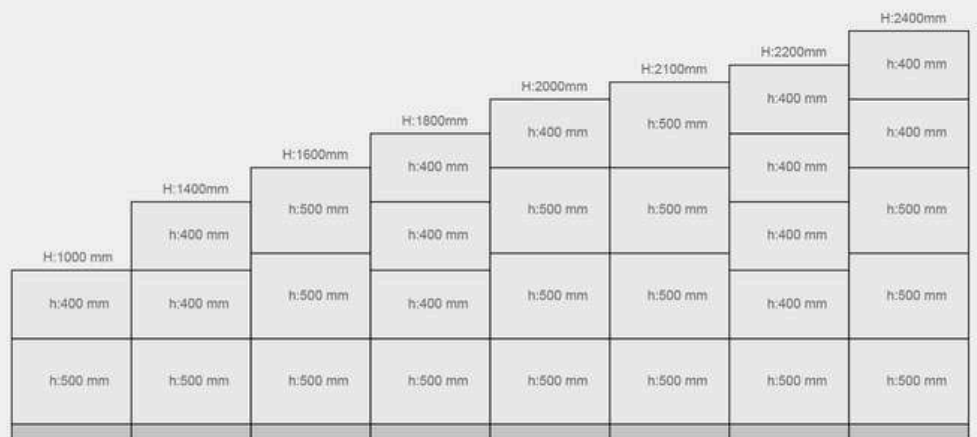
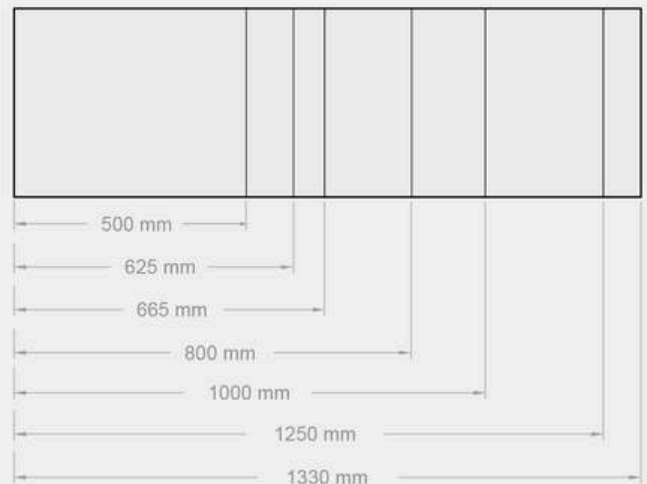
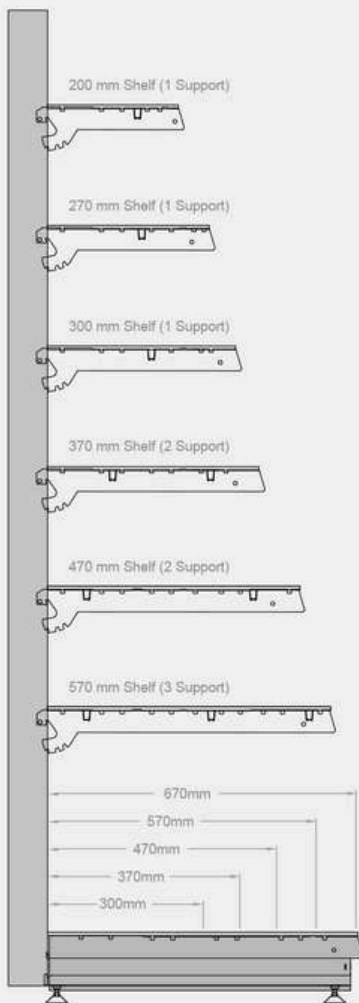

F60 MINIRACK SYSTEM



Durable and Efficient Storage Solution

F60 Minirack System is preferred for light-to-medium load weights, offering an optimum load capacity with its 60 mm upright dimension.

With different profile types and sections, the horizontal beams of the F60 System can bear loads up to 550 kg per level.

F60 Rack System can be used fully compatible with S35 Rack system to offer in-line combined installations.

F60 MINIRACK SYSTEM

UNIT ENTEGRATED SYSTEM

** It is fully compatible with the S35 Metal Shelving System. Shelving unit is fully integrated as a single upright system.

** In case of S25 or S50 shelving system, a three upright full shelving unit is required and used as an "inserted" shelving unit.



THREE LEG SYSTEM

** It is a lightweight storage rack system designed to create deeper shelving spaces. Its durable structure and modular design allow efficient use of warehouse space. It provides a flexible and organized storage solution by adapting to different product groups.



F60 TECHNICAL DETAILS

F60 FRAME

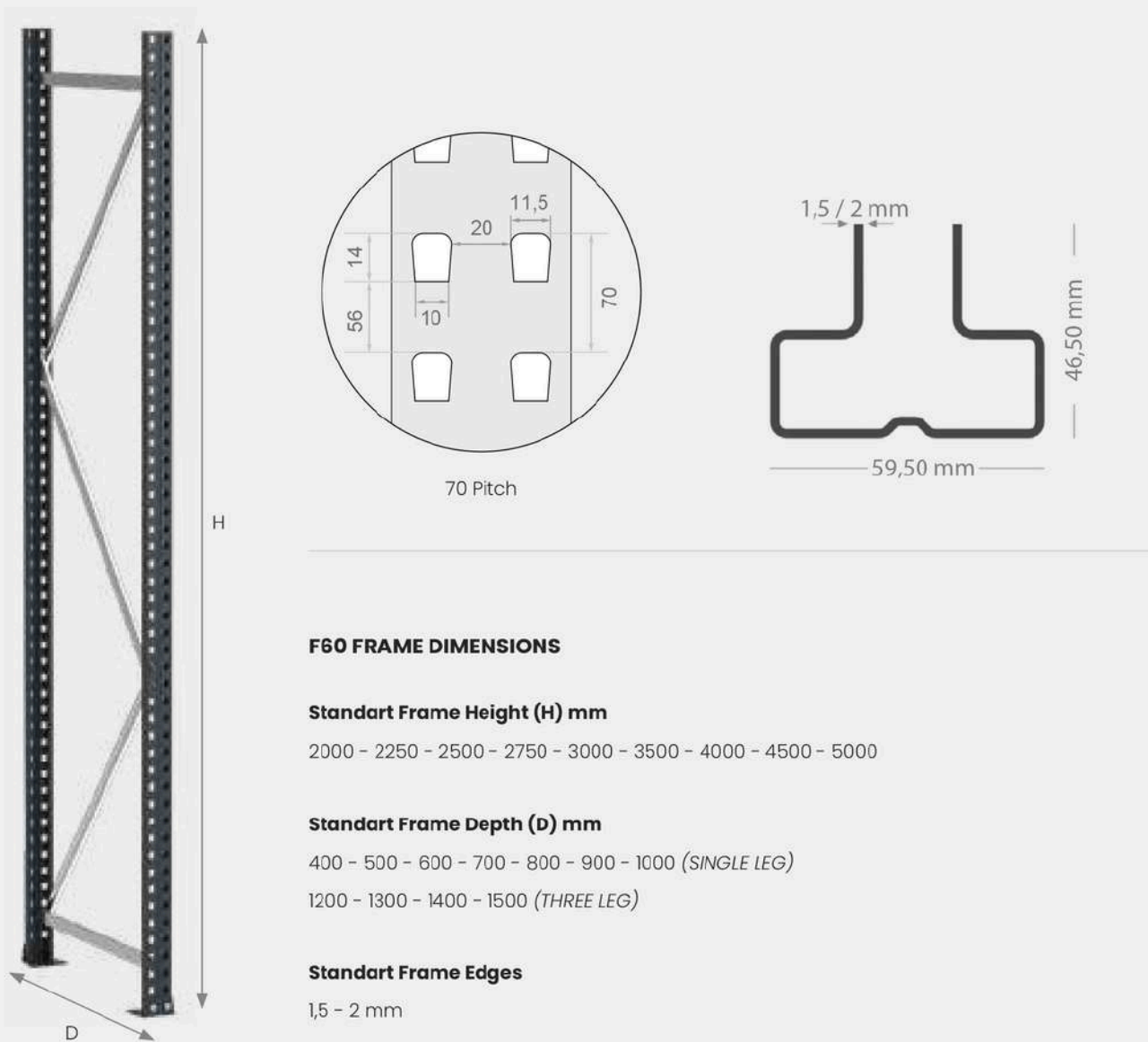

F60 FIXING PARTS

<p>F60 Base Plate</p> 	<p>F60 Steel Peg</p> 	<p>F60 Security Pim</p> 	<p>F60 Frame Wall Connection</p> 	<p>F60 Frame Interconnection</p> 
<p>39 x 86 x 71 mm</p>			<p>100 - 150 - 200 mm</p>	<p>100 - 150 - 200 mm</p>

F60 BEAM PROFILES

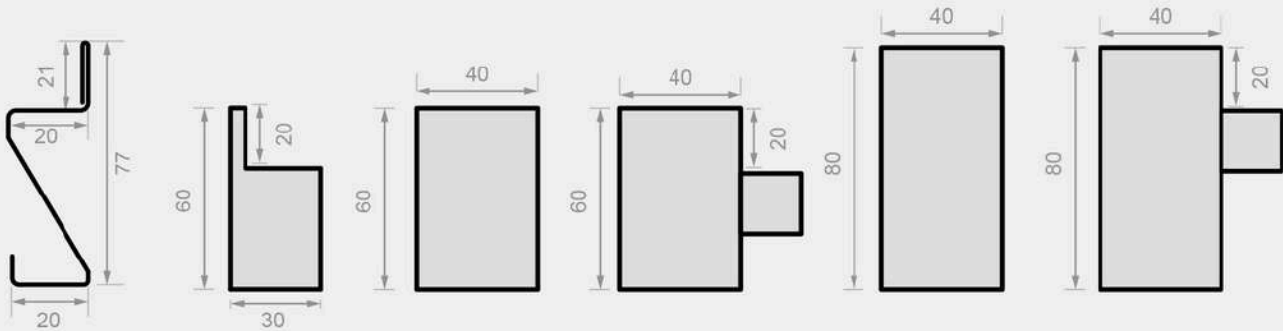

Beam Floor Load Carrying Capacities							
Beam Edge	1000 mm	1250 mm	1500 mm	1750 mm	2000 mm	2250 mm	2500 mm
F60 Z BEAM 66. (1,5 mm)	640 Kg	600 Kg	560 Kg	480 Kg	420 Kg	410 Kg	400 Kg
F60 Z BEAM 66. (2 mm)	810 Kg	760 Kg	710 Kg	600 Kg	550 Kg	440 Kg	420 Kg
F60 OMEGA BEAM 30x60 (1,5 mm)	1150 Kg	860 Kg	660 Kg	550 Kg	500 Kg	460 Kg	410 Kg
F60 OMEGA BEAM 30x60 (2 mm)	1200 Kg	1060 Kg	840 Kg	700 Kg	620 Kg	580 Kg	560 Kg
F60 BOX BEAM 40x60 (1,5 mm)	1200 Kg	860 Kg	700 Kg	660 Kg	540 Kg	500 Kg	440 Kg
F60 BOX BEAM 40x60 (2 mm)	1340 Kg	1100 Kg	880 Kg	770 Kg	640 Kg	600 Kg	550 Kg
F60 BOX BEAM 40x80 (2 mm)		1900 Kg	1600 Kg	1350 Kg	1200 Kg	1170 Kg	1000 Kg
F60 BOX G BEAM 40x80 (2 mm)		1950 Kg	1650 Kg	1400 Kg	1300 Kg	1250 Kg	1070 Kg

F60 TRAYS

Internal Tray

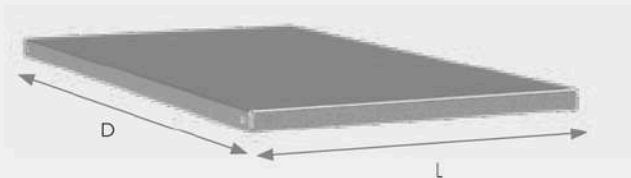

External Tray

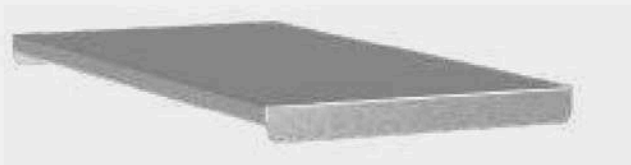

F60 FRAME DIMENSIONS

Standart Tray Depth (D) mm

400 - 500 - 600 - 700 - 800 - 900 - 1000 (SINGLE LEG)
1200 - 1300 - 1400 - 1500 (THREE LEG)

Standart Tray Length (L)

250 - 300 mm

Standart Tray Height (H)

20 mm

Standart Tray Edges

0,8 - 1 - 1,2 - 1,5 mm

CHECKOUTS

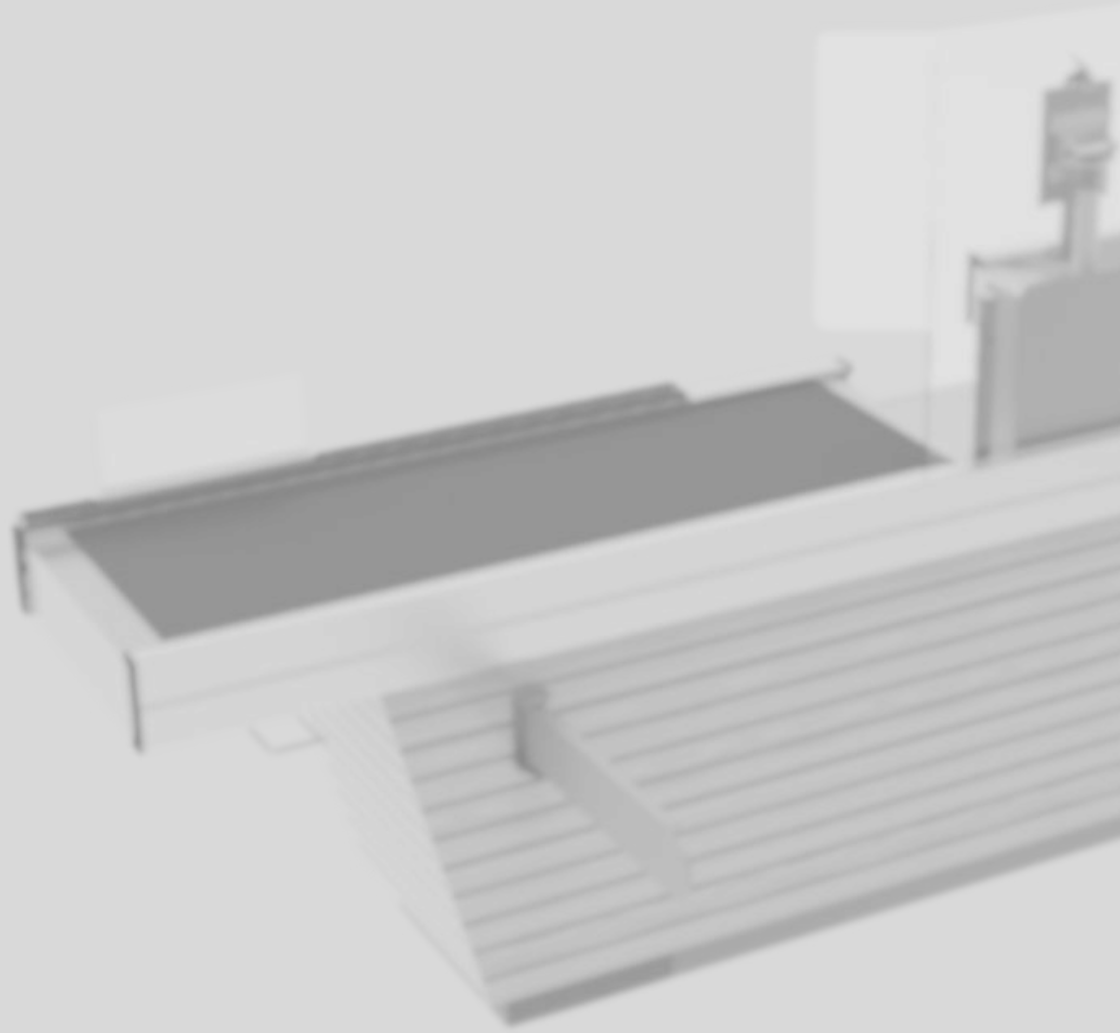

Innovative, Stylish, and Functional Checkout Solutions

Designed to meet the needs of the modern retail world, our checkout systems combine aesthetics and functionality to create an efficient workspace. With ergonomic structures, durable materials, and smart design details, they enhance cashier comfort while improving the customer experience. Offering a wide range of models to suit different store concepts, we provide the ideal solutions for a fast and organized checkout process.

INOVA CHECKOUT



Lenght

2500-2800-3000

3300-3500-3800

Inova– Fast, Secure, and Modern Checkout Experience

Inova is an innovative checkout system designed to maximize speed and efficiency in the retail world. With its ergonomic design, smart payment solutions, and durable materials, it offers a seamless shopping experience for both businesses and customers.

Its modern design seamlessly integrates into any store environment, reducing transaction times and boosting productivity while ensuring a comfortable working experience for cashiers. Strong, sleek, and highly functional, Inova is the checkout solution of the future.

INOVA CHECKOUT

WOODEN COVERED

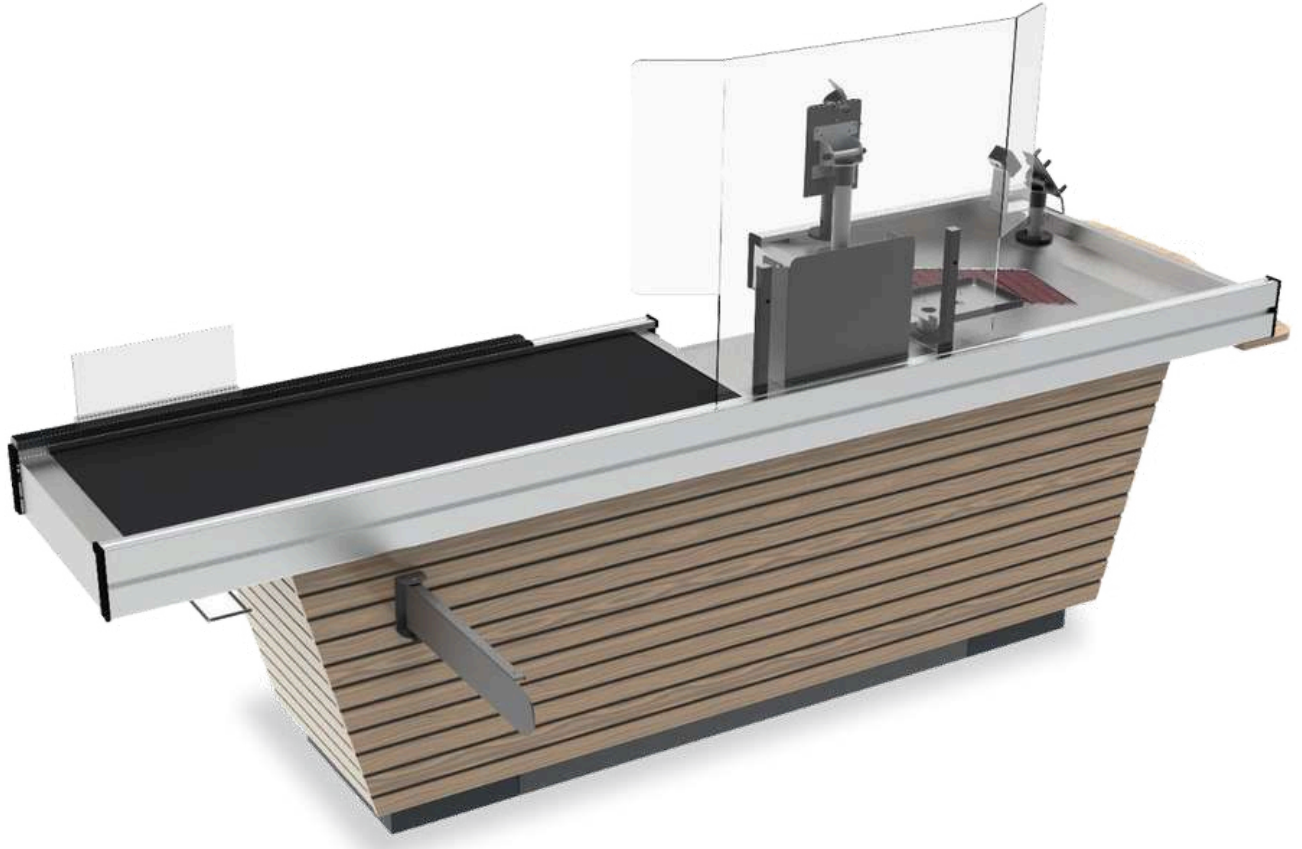

Lenght

2500-2800-3000

3300-3500-3800

Inova Wood – Natural Elegance and Superior Functionality

The wooden-clad version of Inova offers a warm and aesthetic appearance while maintaining the speed and efficiency of modern checkout systems.

With its durable materials, ergonomic design, and spacious functionality, it ensures a comfortable shopping experience for both businesses and customers. Combining the elegance of wood with practicality, it is the perfect checkout solution that balances style and efficiency.

SPEDOX EXPRESS CHECKOUT



Length
1400-1600-1800

Spedox – Fast and Seamless Express Checkout

Spedox is a high-speed, practical, and efficient express checkout solution. Designed to ensure a smooth payment flow in busy retail environments, this model enhances both cashier and customer comfort with its ergonomic structure and spacious shelving.

Built with durable materials and a modern design, Spedox offers long-lasting performance, making it the perfect choice for a seamless and organized shopping experience.

FRUIT & F&V
VEGETABLES
DISPLAYS



Solutions That Bring Freshness and Order Together

Create a natural atmosphere in your store with stylish, functional, and flexible solutions designed for fruit and vegetable sections. Ergonomic designs ensure optimal product display while maintaining order and enhancing the customer experience. With durable materials and smart display systems, offer both aesthetics and efficiency in your shopping space. Discover solutions that highlight freshness, improve accessibility, and strengthen your store's identity!

VEGY SINGLE LAYER WALL UNIT

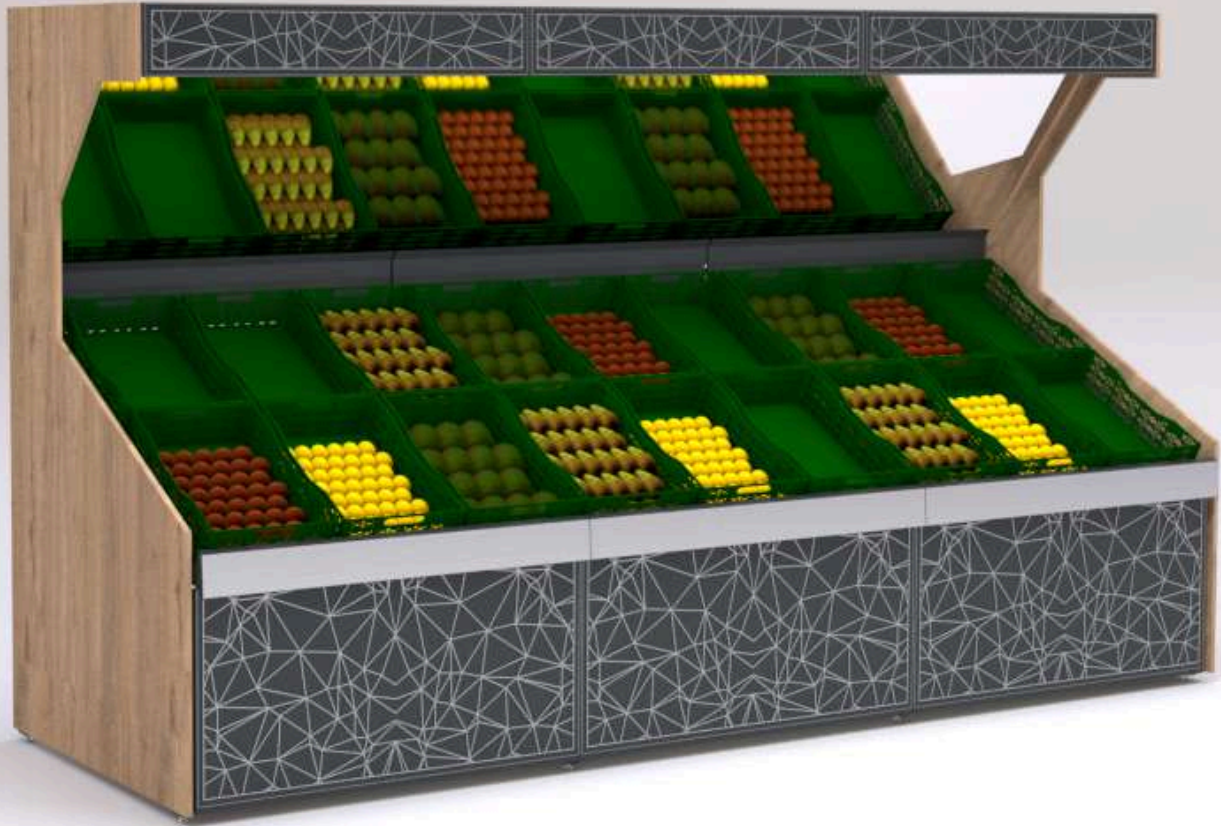

Natural Elegance, Modern Design

Covering Options



Metal

Modern

Wood

Paneling

Designed with the warm texture of wood and modern geometric details, Vegy offers a spacious display area and an ergonomic structure to showcase your products at their best.

Its durable materials and modular design ensure compatibility with any market space, enhancing the shopping experience with both aesthetics and functionality.

Unit Dimension

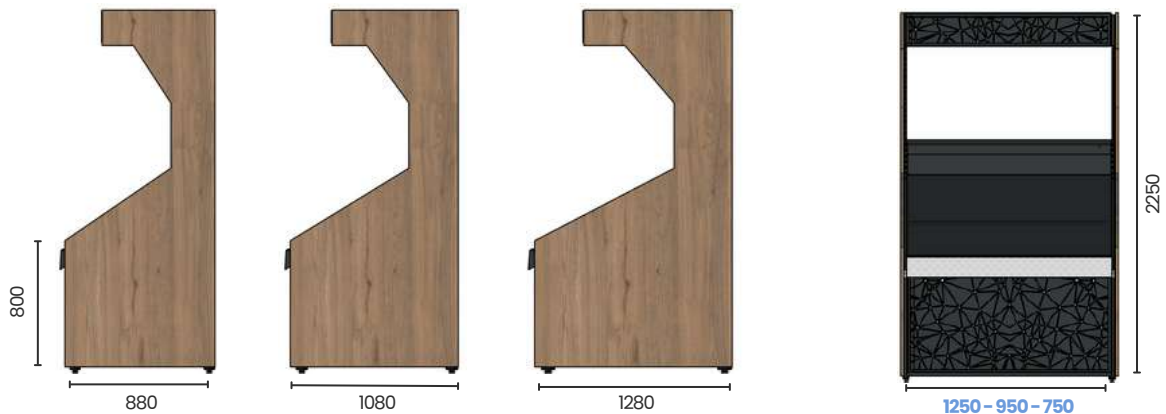

VEGY DOUBLE LAYER WALL UNIT



Maximum Space, Modern Design

With its double-layered structure, Vegy Double offers expanded display capacity while combining elegance and functionality with natural wood details and modern lines.

Its ergonomic incline and durable construction ensure seamless integration into any market space, enhancing the shopping experience with a more organized and visually appealing presentation.

Covering Options



Unit Dimension

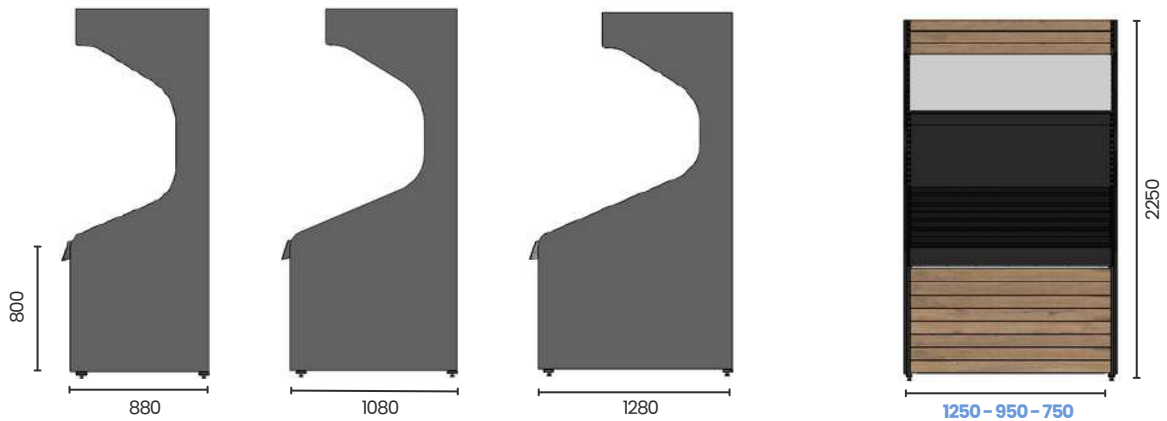

VEGY GONDOLA



Where Elegance Meets Organization

Bringing style and order to the heart of your market, Vegy Gondola stands out with its spacious display area and natural wood details.

Integrated label holders and additional accessory sections enhance usability, while its sturdy structure ensures a long-lasting and visually appealing solution.

Covering Options



Unit Dimension

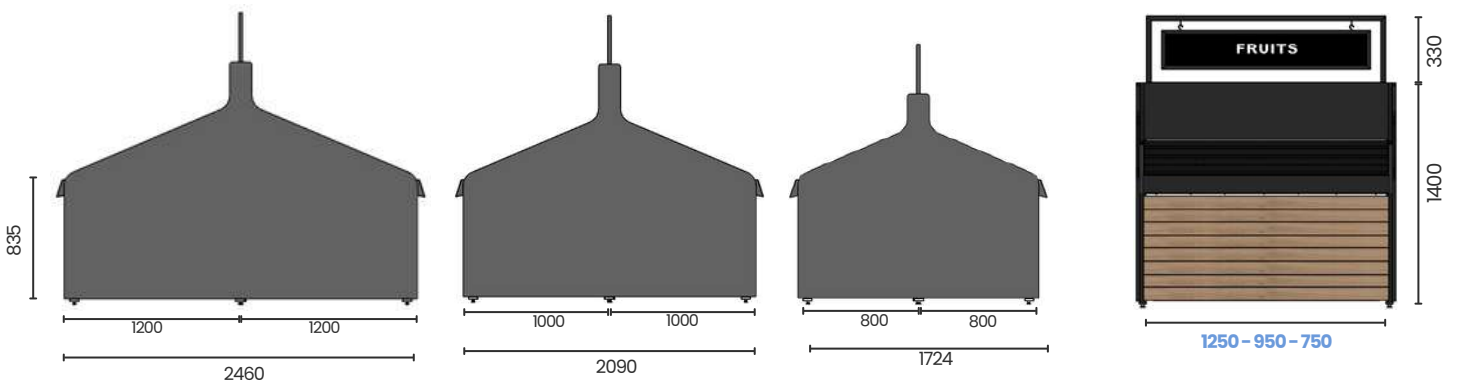

VEGY HEAD GONDOLA



Eye-Catching and Functional

Vegy Head Gondola enhances market organization while providing an attractive display area. Designed to seamlessly complement Vegy Island, it highlights your products, boosting visibility and sales.

With its durable structure, natural wood details, and additional accessory space, it combines aesthetics and functionality effortlessly.

Covering Options



Metal

Modern

Wood

Paneling

Unit Dimension

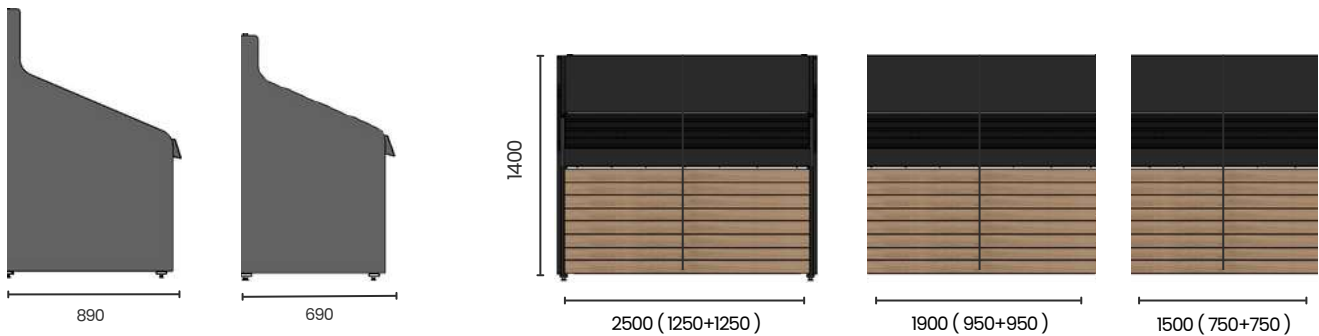

VERDE WALL UNIT

NEW



Nature-Inspired Modern Display

With its elegant wood texture and innovative design, Verde blends natural aesthetics with modern functionality, creating a sophisticated display area in markets.

Its three-tier structure maximizes product visibility, while the ergonomic incline and spacious layout ensure ease of use. Built for durability and designed for style, Verde enhances the shopping experience by making it more organized and inviting.

Covering Options



Unit Dimension



VERDE GONDOLA

NEW



Spacious Display, Elegant Design

Bringing nature and organization to the heart of your market, Verde Gondola offers a large display capacity to showcase your products at their best.

With its wooden texture and modern lines, it provides a stylish appearance while ensuring ease of use through its ergonomic design. Its sturdy and functional structure enhances the shopping experience by making it more organized and efficient.

Covering Options



Unit Dimension

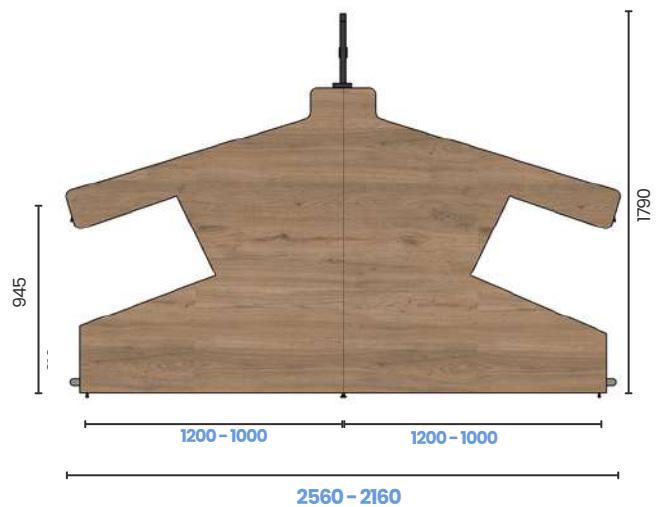

VERA WALL UNIT

NEW



Covering Options



Marble

Modern



Wood

Paneling

"Every Display Transformed into Art by VERA!"

VERA is a versatile fruit and vegetable stand that allows you to create various displays by combining flexible accessory options.

With its diverse visual coverings, VERA adapts to every taste and concept. It truly acts as a sales booster for your stores! This stand showcases your fresh products in the best way, attracting customer attention and increasing sales.

Unit Dimension

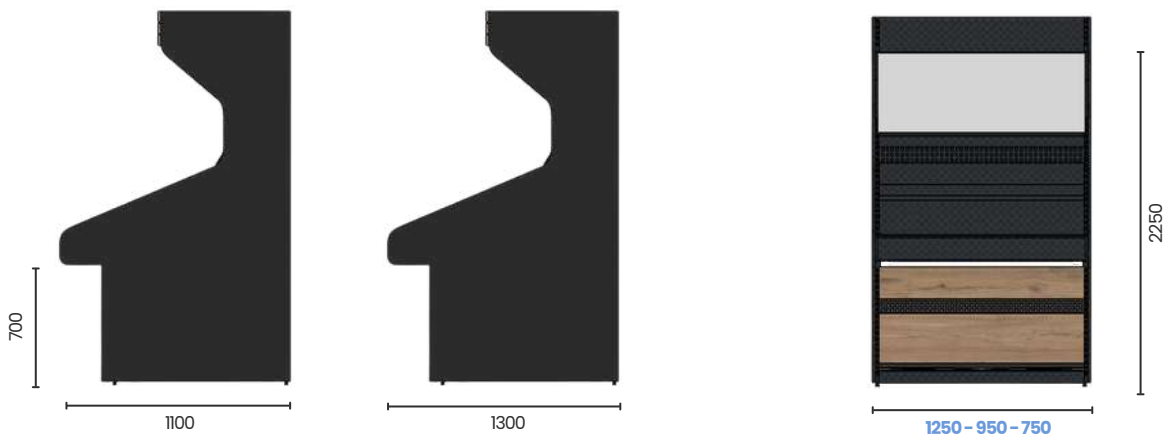

VERA GONDOLA

NEW



“Boost Sales with VERA’s Eye-Catching Display”

Covering Options



Marble

Modern



Wood

Paneling

VERA is a dynamic centerpiece solution for your store, combining modern design with flexible accessory options.

With various covering alternatives, it seamlessly adapts to any decor style, showcasing your fresh products in the most eye-catching way. VERA not only provides an aesthetic display area but also boosts customer engagement, directly contributing to your sales performance.

Unit Dimension

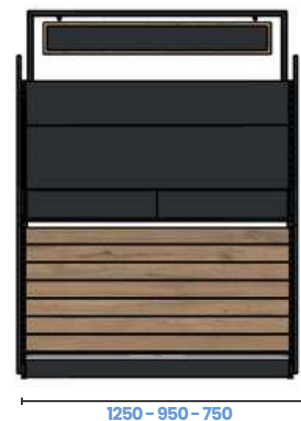
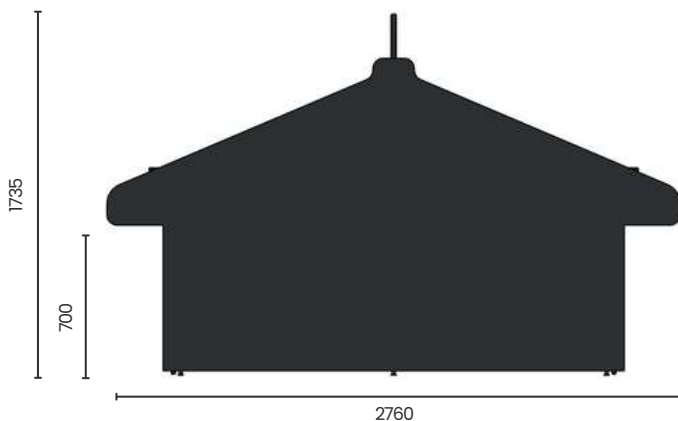

NEW

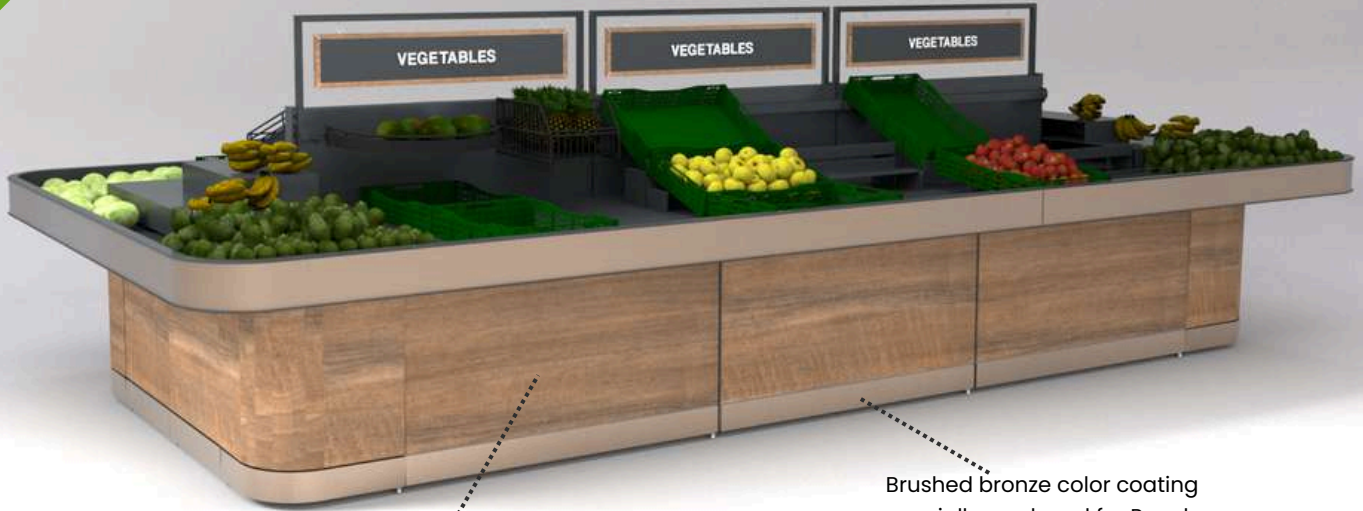

Special wooden laminated color for ROYAL.
Water and moisture resistant coating.

Brushed bronze color coating
specially produced for Royal

STYLISH, POWERFUL, AMBITIOUS

Royal Island offers a variety of accessories and display options to create your own produce presentation. The F&V cases can be displayed in multiple angles vertically. The case vertical riser allows you to display the cases at different angles. There are also different shelf, basket and podium options for packed or bulk display.

Covering Options

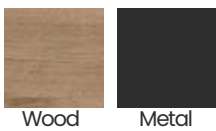

Unit Dimension





ORCA - A Design that Shapes Freshness

ORCA redefines the experience of displaying fruits and vegetables with its nature-inspired aesthetic and functional design. The warmth of the wooden texture combined with modern lines brings together naturalness and elegance in shopping spaces. Its modular structure adapts to any need and creates impressive displays. Additionally, its unique design transforms the central areas of your fruit and vegetable sections into a natural space, enriching the shopping experience and increasing customer interest.

Covering Options



Unit Dimension

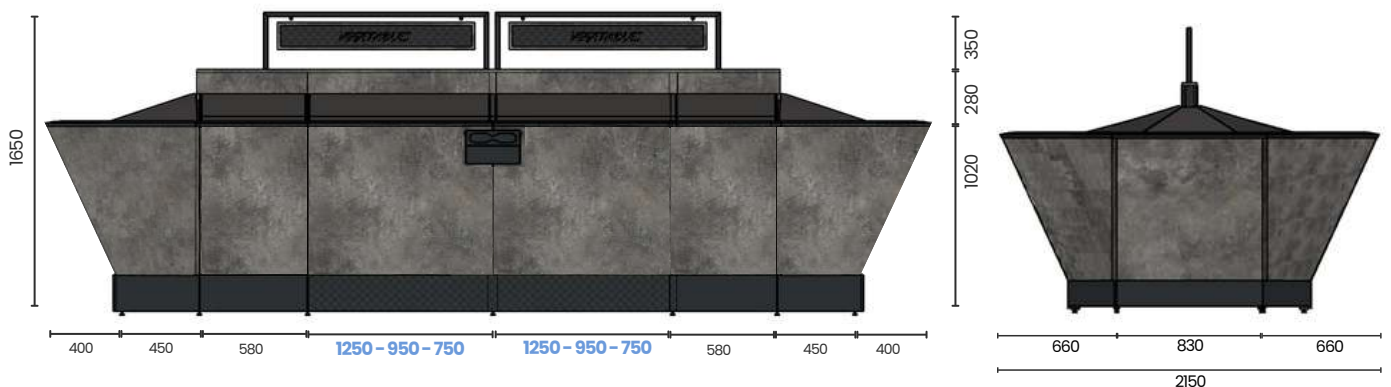

VENDURA ISLAND

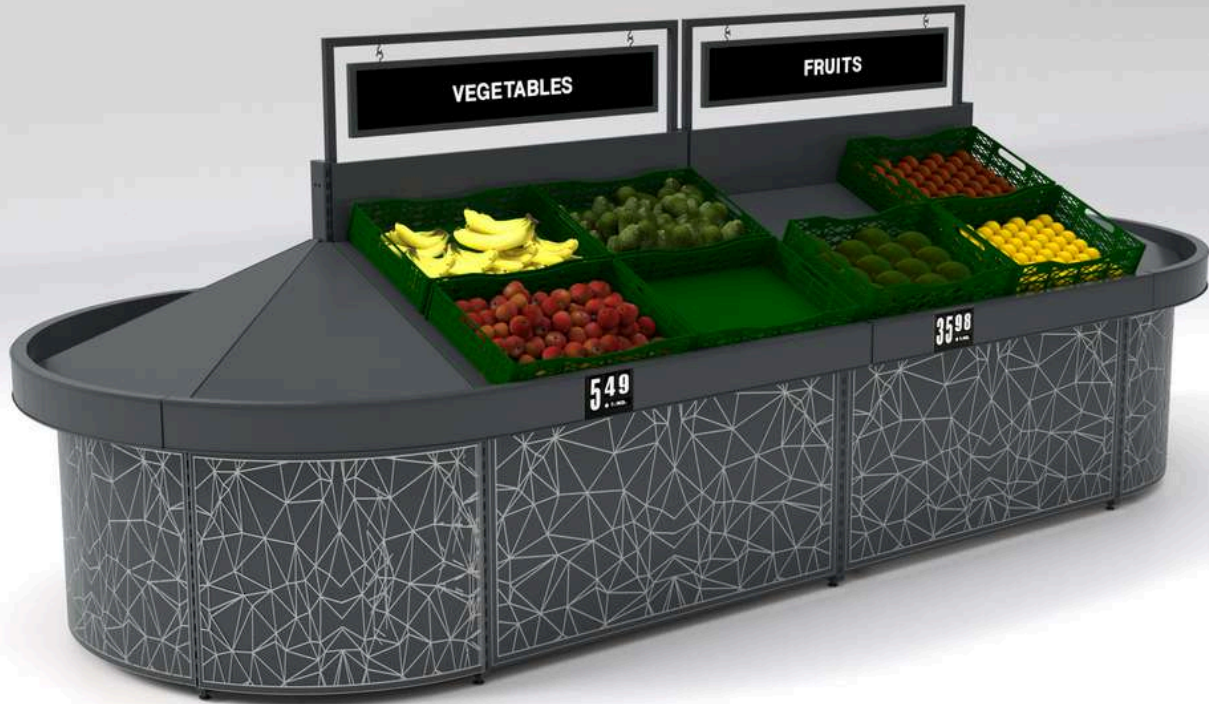

Vendura: A Fresh Breeze for Your Store

Introducing Vendura, the ultimate solution for showcasing your fruits and vegetables. Its elegant oval display design not only enhances the natural appeal of your products but also ensures seamless navigation in high-traffic areas. Combining aesthetic sophistication with functional efficiency, Vendura transforms your store into an inviting and organized space, perfectly balancing style and usability.

Covering Options

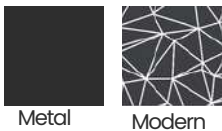

Unit Dimension

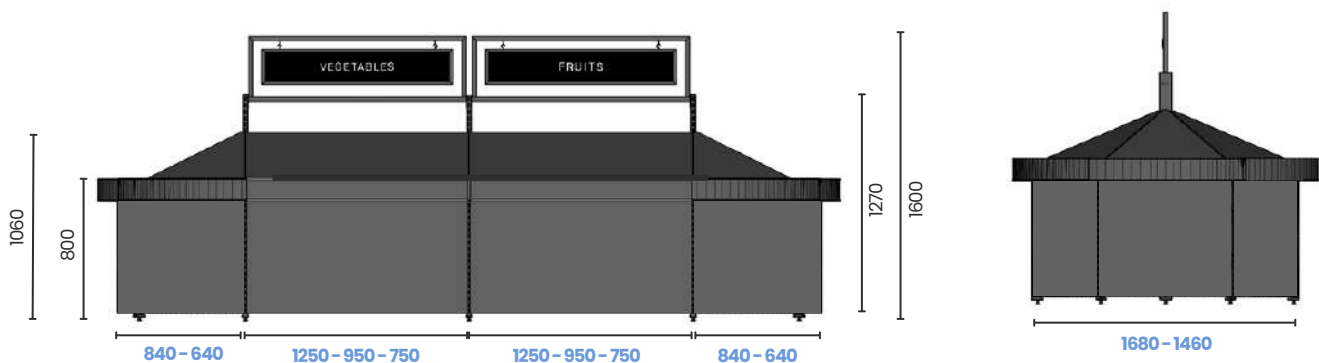

DYNAMIC WALL UNIT



Flexibility Meets Style

With its modular design, Dynamic adapts to various product groups, offering a functional and aesthetic solution for fruit and vegetable displays. Its open shelving system ensures easy access to products, while the durable metal frame and natural wood details provide a modern look. Featuring a spacious display area and adjustable shelves, Dynamic is the ideal unit for enhancing organization and efficiency in markets.

Covering Options



Unit Dimension

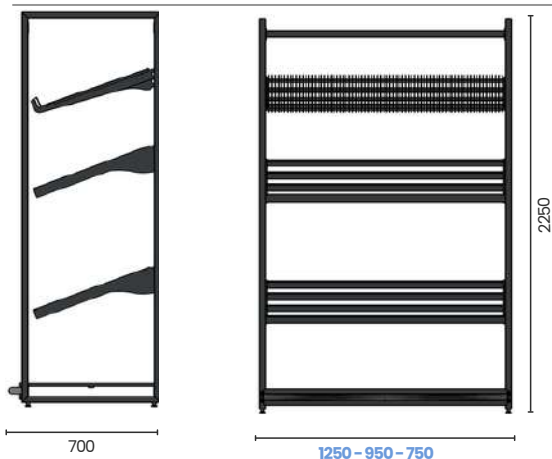

GREENS WALL UNIT



Where Freshness Meets Elegance

With its modern design and spacious display area, Greens offers a stylish solution that highlights the freshness of fruits and vegetables in markets. Its multi-tier structure ensures maximum product visibility, while the integrated glass panel provides both protection and aesthetics. Featuring a natural wood texture and a durable build, Greens enhances the shopping experience by making it more organized and visually appealing.

Covering Options

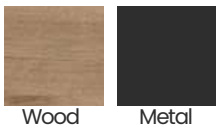

Unit Dimension

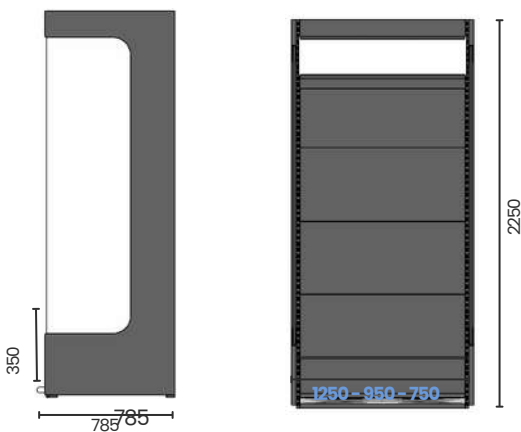

GREENS ROUND SHELF



Stylish and Functional Display for Fresh Produce!

Greens is a modern and durable unit designed to showcase fruits and vegetables in the best way. Its oval shelves ensure a more organized and visually appealing display, while natural wood details add an elegant touch. Offering maximum visibility and ease of use, this design enhances freshness and improves the shopping experience.

Covering Options

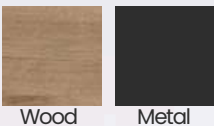

Unit Dimension

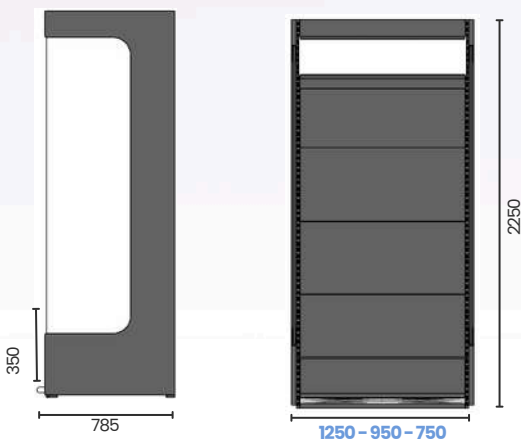

BLOOM F&V STAND

NEW



Mobile and Flexible Display Unit

With its compact and functional design, Bloom provides a practical solution for displaying fruits and vegetables. Its adjustable tilt angle ensures optimal product visibility, while the wheeled structure allows for easy mobility and flexibility. Lightweight yet durable, Bloom is the ideal solution for quick and efficient displays in markets.

Unit Dimension

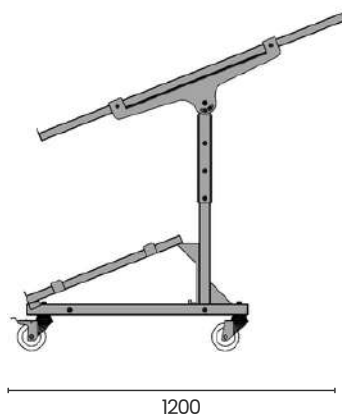
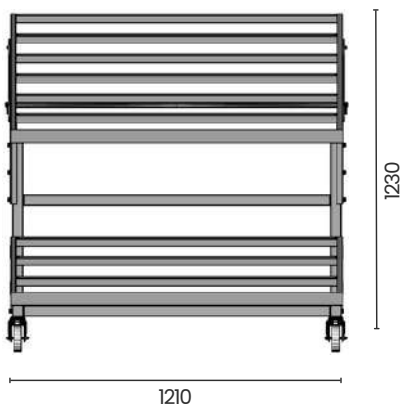

angle adjustable
top table

SEC DISPLAY STAND



Compact and Efficient Display Solution

With its sleek and functional design, Sec maximizes display capacity even in limited spaces. Its tiered shelving structure allows for an organized and accessible product presentation, while the sturdy metal frame enhances durability. The open design supports ventilation to maintain freshness, making Sec both a stylish and practical solution for modern markets.

Unit Dimension

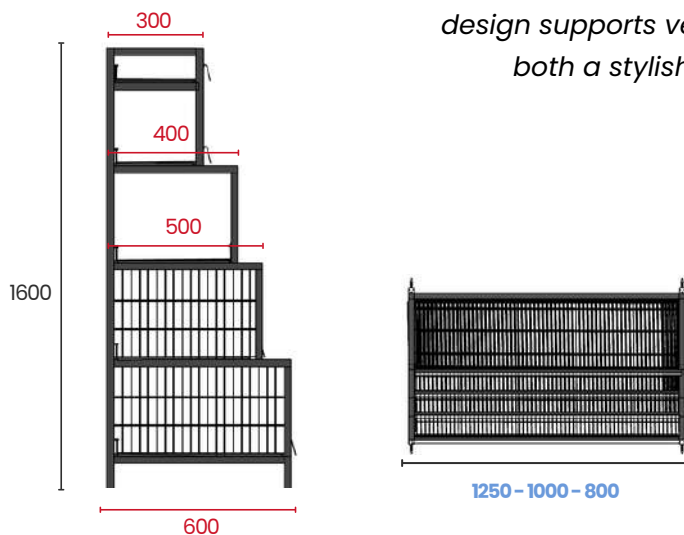

GREAT DISPLAY STAND



400 Kg Capacity



Practical and Stylish Display Solution

With its minimalist design and sturdy structure, Great is the perfect display unit for bulk products. The wooden panels offer a natural aesthetic, while the metal frame enhances durability. Its wheeled design allows for easy mobility and flexible use. Providing both organization and visibility, Great is a functional solution for modern markets.

Unit Dimension Options (hxdxl)

- 850 x 600 x 600 850 x 800 x 800
- 850 x 600 x 800 850 x 800 x 1000
- 850 x 600 x 1000 850 x 800 x 1200
- 850 x 600 x 1200
- 850 x 1000 x 1000
- 850 x 1000 x 1200
- 850 x 1200 x 1200



850

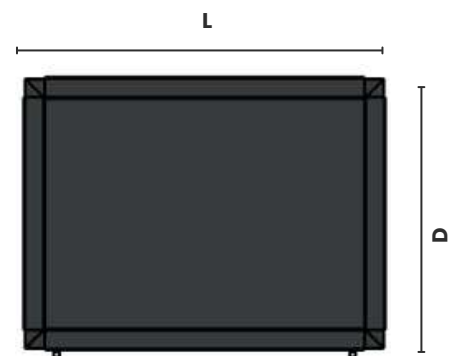

L

D

SCALES DESK SAMPLE MODULES



SCALES DESK SINGLE

(hxcxl) 1000 x 640 x 600

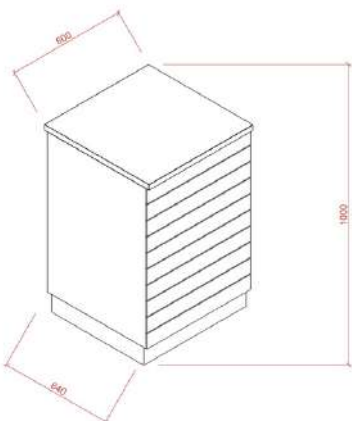

SCALES DESK DOUBLE

(hxcxl) 1000 x 640 x 1200

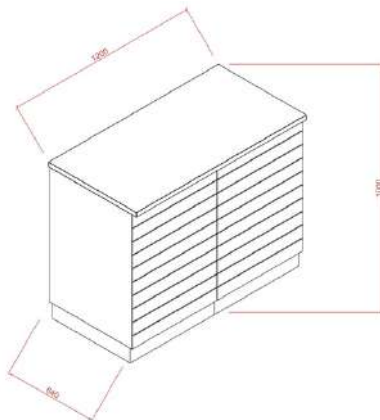

SCALES DESK CORNER

(hxcxl) 1000 x 640 x 640

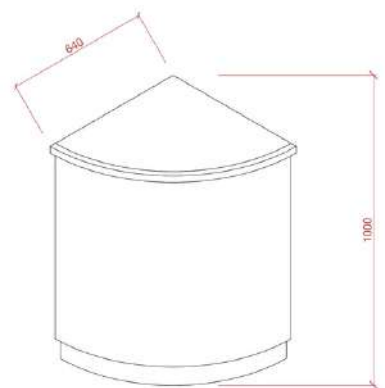

BAKERY DISPLAYS



Smart Solutions That Highlight Flavor

Designed specifically for baked goods, our display units prioritize freshness and hygiene while ensuring safe and easy access for customers. With modern aesthetics, they enhance your store's ambiance, creating a warm and inviting atmosphere. Durable materials, smart storage, and efficient display solutions keep your products both visually appealing and well-organized. Combining functionality, elegance, and ease of use, these solutions help you create the perfect bakery section!

KIOS WALL SYSTEM



Versatile Elegance for Perfect Bakery Displays

KIOS is a multifunctional display system for baked goods, which blends a variety of materials, such as wood, metal, wire and plexiglass, in a harmonious and stylish design.

KIOS provides the retailer the maximum efficiency in product presentation thanks to its vast variety of exchangeable and adjustable shelves, cabinets and accessories.

COMPATIBLE S25
SYSTEM



Modular Flexibility for an Optimized Bakery Display

It's very straightforward to create a complete sales area for baked goods by using the wall and gondola units together, offered in different measures of depth/ length which help the retailer achieve an efficient use of space.

KIOS is fully compatible with the accessories that are part of the Sova Product Ecosystem.

The modular industrial design ensures a safe and easy transport along with an effortless assembly.

COMPATIBLE S25
SYSTEM

GRANO WALL SYSTEM



GRANO – Hygienic, Stylish, and Functional

GRANO is designed to showcase your baked goods in the most hygienic and aesthetic way. With its transparent lids, it protects the products while its ergonomic structure provides easy access for customers. Complementing your store's atmosphere with its modern and organized design, GRANO offers maximum hygiene and ease of use.

COMPATIBLE S25
SYSTEM

DYNAMIC DISPLAY SYSTEM



DYNAMIC-Flexible and Stylish Bakery Display Unit

Dynamic Bakery is a modular display unit designed specifically for baked goods, offering flexible usage options. Combining wood, metal, and wire details, it creates a warm yet modern atmosphere while adjustable shelves and accessories provide the perfect display space for each product. With its functional design, Dynamic Bakery ensures efficient space utilization in stores, delivering both an aesthetic and practical display experience.



COMPATIBLE S25 SYSTEM

PANERA BAKERY DISPENCER



PANERA bakery dispenser is a free standing display that is used as a self-service stand for baked goods. Tempered glass lids provide product visibility and hygiene. Drawers with telescopic rails and inclined base offer ease of use.



PANERA BAKERY DISPENSER

WITH BANNER



You can create module groups of any length you want by placing the Panera Bakery dispenser side by side in double and triple modules.



DOUBLE MODUL

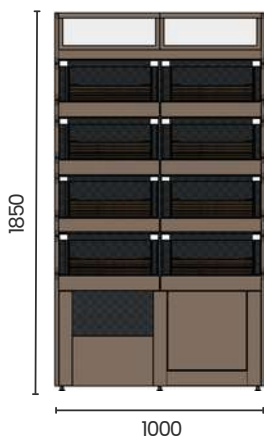

TRIPLE MODUL

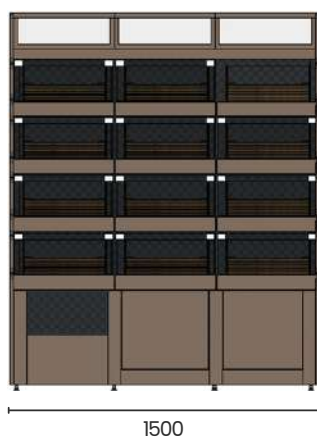

DEPTH



**DISPLAY
STANDS**



Stylish and Functional Display Baskets

Display baskets are designed to showcase your products in an organized and eye-catching way. Available in various sizes and designs, they adapt to any store layout, offering flexible use. Crafted from durable materials with natural textures, they provide both an aesthetic look and easy customer access. Maximize your display efficiency with practical and stylish solutions!

CRUST DISPLAY ISLAND



Elegant Presentation for Baked Goods

With its natural wood details and sturdy metal structure, Crust is designed to showcase baked goods at their best. Its modular design adapts to various layouts, offering a spacious display area. Basket accessories and multi-tier shelving keep products organized and accessible, while its wheeled structure allows for easy mobility within the store. Crust combines aesthetics and functionality, making it the perfect bakery display unit.

Unit Dimension

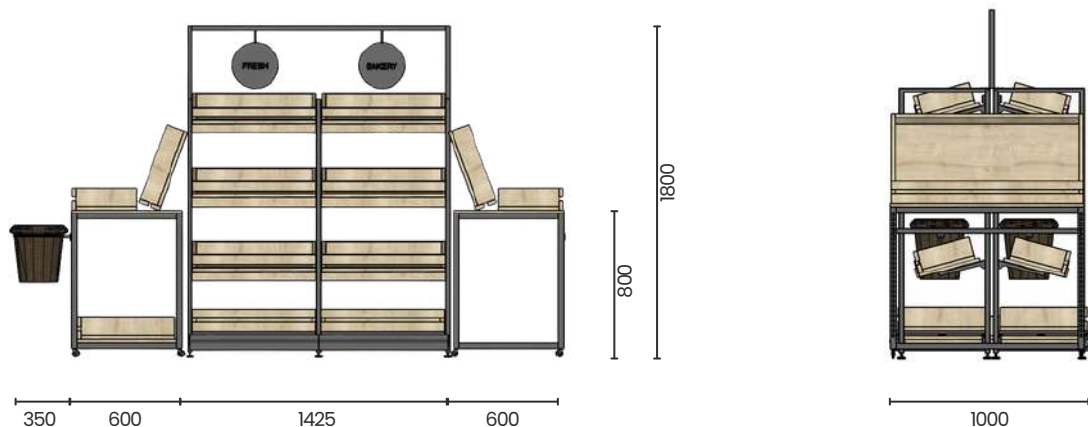

GRIDY DISPLAY STAND

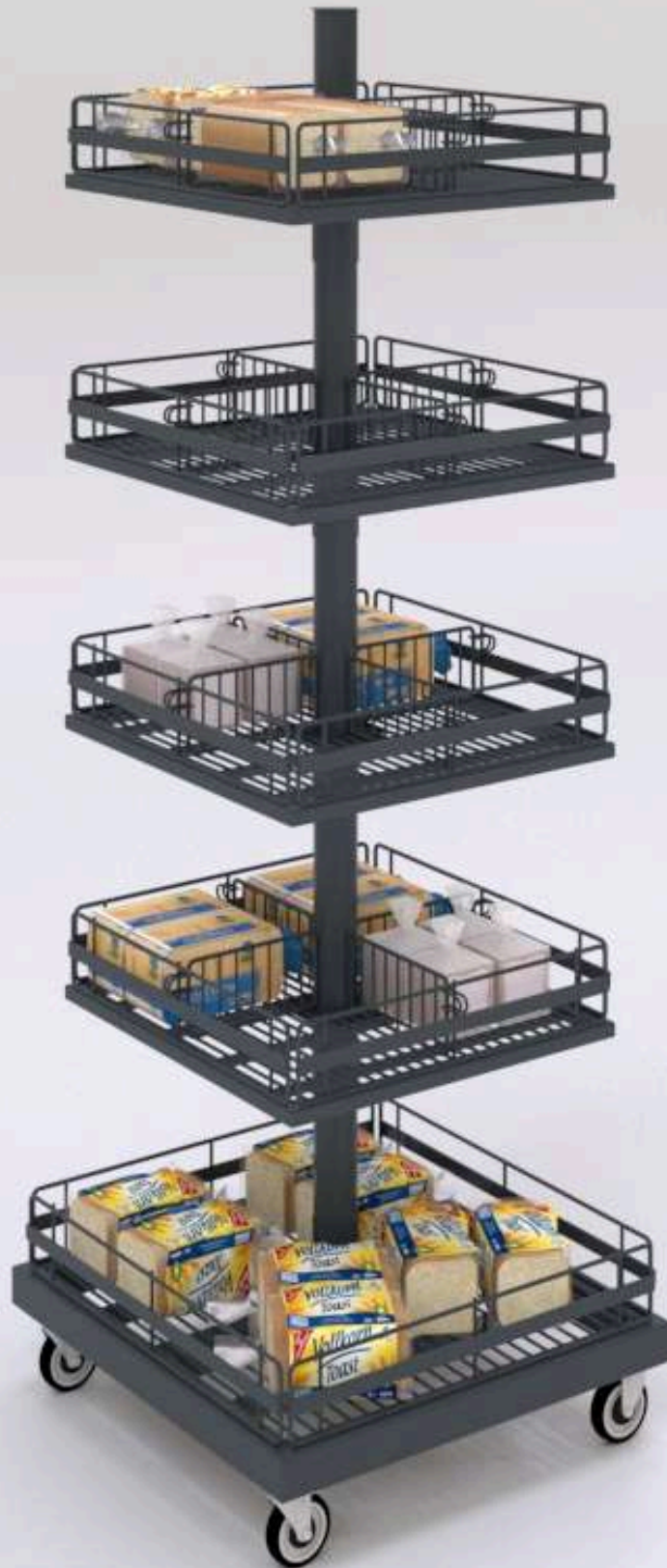

Optional Signage



Adjustable Shelves

GRIDY – Maximum Efficiency, Minimum Space

Gridy is an innovative display unit designed for the modern retail world. Its vertical structure allows maximum product showcasing even in limited spaces. With its mobile wheels, it offers flexible use, while the modular shelf system easily adapts to different product categories. Enhance organization and accessibility in your store with Gridy!

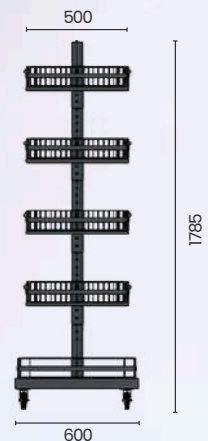

Z-GON DISPLAY STAND



Z-GON – Smart and Flexible Display Solution

Z-GON features a modular design that adapts to various product groups, optimizing space efficiency. Its sleek and functional structure ensures an organized and accessible display, enhancing the customer experience.

Unit Depth Options

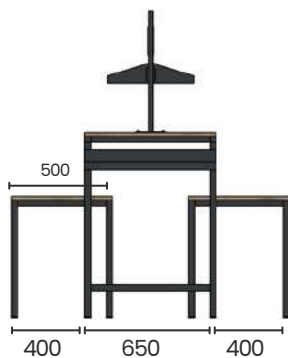

Unit Height / Length Options

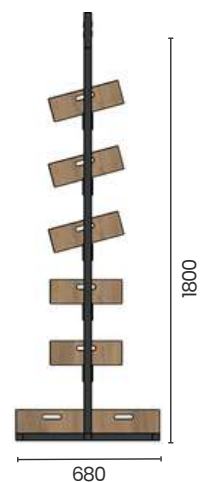
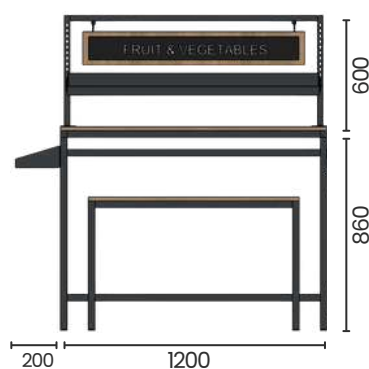

S-GON DISPLAY STAND

PARTS (hxdxI)

S-GON TABLE 860*650*1200

METAL SHELF 200*650

WOODEN SHELF SET 200*1200

WOODEN CASE 100*300*500

WOODEN CASE 150*300*500



S-GON – Flexible and Stylish

S-GON's modern design fits any store layout. Its compact structure optimizes space, while versatile shelves offer flexibility for various products. A practical and aesthetic solution.

Unit Depth Options

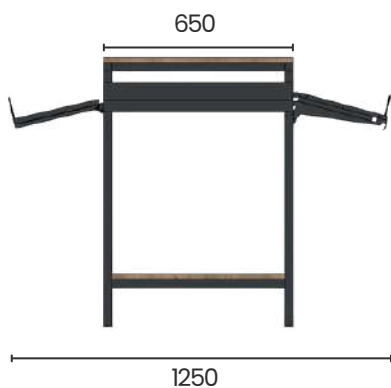

Unit Height / Length Options

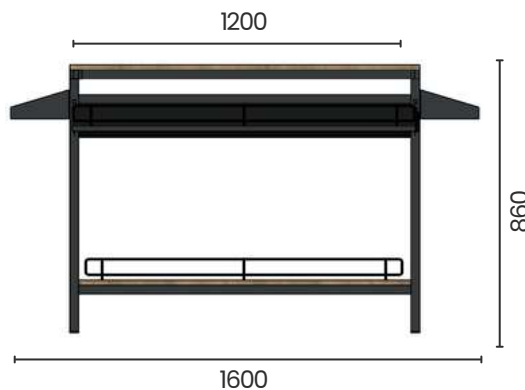

WOODEN CASE

100 x 300 x 500

150 x 300 x 500



LIBERTY DISPLAY BASKET



"Custom prints for every product category and promotion – just the way you want!"

LIBERTY – Bring Freedom to Your Store

Liberty redefines freedom in in-store display with its flexible and functional design. Lightweight, durable, and mobile, it allows you to showcase your products effortlessly wherever you need. Ideal for promotions, discounts, and special offers, Liberty enhances organization and accessibility in your store.

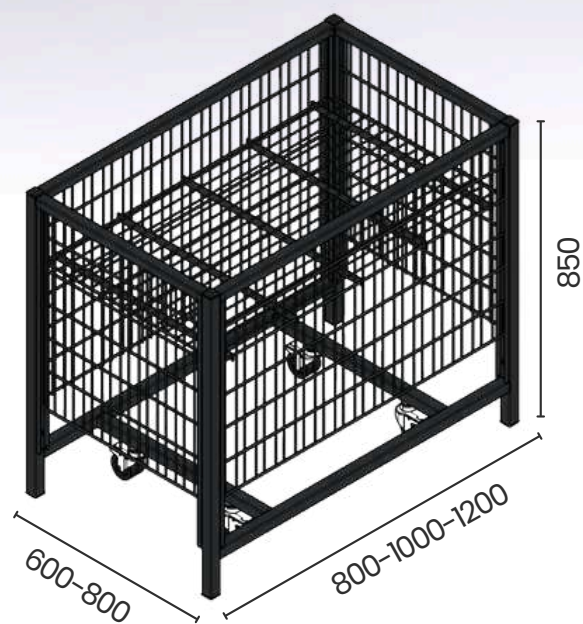

FRESCO DISPLAY BASKET



Compact and Elegant Display

Fresco is a compact display unit designed to showcase baked goods in an organized and accessible way. Combining wood and metal for a stylish appearance, it features a wire shelf at the bottom and a wooden panel on top, ensuring optimal presentation for different products. Lightweight and portable, Fresco can be easily positioned within the store, offering both practicality and elegance.

Unit Dimension

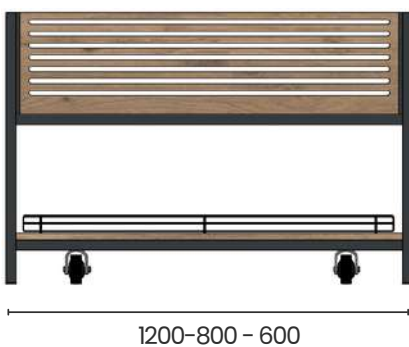

DELTA DISPLAY BASKET



Offers flexible and powerful presentation with its double-layer basket. Higher mobility with optional wheels. Easy display of prices with the price tag slots on the sides of the basket.

A very handy top basket, compatible with ALFA, BETA, GAMA and DELTA model display baskets. Additional presentation space with 2 additional shelves. Easy display of prices with included channels for price labels. With its symmetric structure, it can be used from both sides of the basket.



DISPLAY BASKET (H x D x L)

850 x 600 x 800 mm
850 x 800 x 1200 mm

TOP BASKET SET (H x D x L)

700 x 320 x 800 mm
700 x 320 x 1200 mm

BETA DISPLAY BASKET



Thanks to the 4-levels adjustable wire shelf of the display basket BETA, it's possible to adjust the presentation depth for different products. With optional lower profile frame, this basket can also handle heavier loads. The optional mobile version with wheels can be easily moved to any desired location in the store.



Wheeled Foot



Supported Foot

DISPLAY BASKET (H x D x L)

850 x 600 x 800 mm
850 x 800 x 800 mm
850 x 800 x 1200 mm

GAMA DISPLAY BASKET



Display basket GAMA offers the deepest presentation option in this range. The wire shelf can be adjusted at 5-levels of depth. The lower profile frame (optional) helps GAMA handle heavy loads. Wheels are also available for higher mobility in the store.



Wheeled Foot



Supported Foot

DISPLAY BASKET (H x D x L)

850 x 600 x 800 mm

850 x 800 x 800 mm

850 x 800 x 1200 mm

MICRON DISPLAY BASKET



With its fully foldable structure, this basket does not occupy any space in the warehouse when not in use. Offers a flexible presentation with 2 alternative sizes. The shelf can be adjusted at 4-levels according to the product to be displayed.

DISPLAY BASKET (H x D x L)

800 x 530 x 530 mm

800 x 800 x 800 mm

MULTI ACTION BASKET

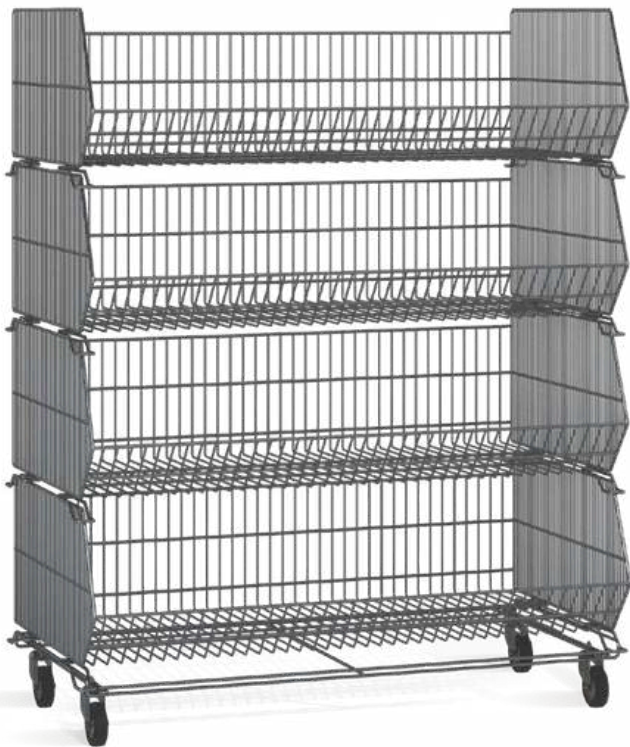

Suitable to be used in every spot in the store, this rack set offers high capacity and mobility. Each tier has a loading capacity of 100 kg.

RACK BASE (H x D x L)	WIRE BASKET RACK (H x D x L)
------------------------------	-------------------------------------

97 x 497 x 1000 mm	264 x 497 x 1000 mm
--------------------	---------------------

97 x 497 x 1250 mm	264 x 497 x 1250 mm
--------------------	---------------------

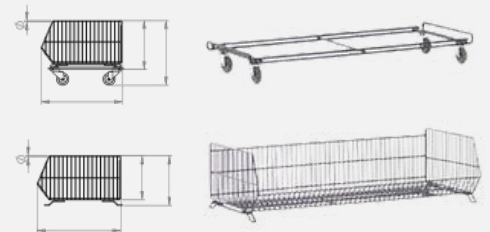

GONDOLA HEAD STAND



An elegant side stand used at the edge of the gondola heads, offering an extra display area.

SIDE BODY (H x D x L)	SIDE SHELF (D x L)
------------------------------	---------------------------

1850 x 200 x 400 mm	180 x 400 mm
---------------------	--------------

1850 x 200 x 500 mm	180 x 500 mm
---------------------	--------------

2060 x 200 x 400 mm	
---------------------	--

2060 x 200 x 500 mm	
---------------------	--

WIRE HOOK DSG (D)

150 mm

WIRE HOOK WITH LABEL DSG (D)

150 mm

MEGA DISPLAY BASKET



Solid built, strong and high capacity display basket. Smaller spacing of the wire grid offers convenience in presenting smaller products. Wheels are standard, giving the basket a higher mobility. The L-shaped post is used to hang the price labels/tags.

DISPLAY BASKET (H x D x L)

630 x 600 x 1000 mm

630 x 800 x 1200 mm

SIGMA DISPLAY BASKET



Offers a high capacity with its deep basket and strong profile legs. Optional wheels add mobility in the store.

Basket depth: 720 mm.

6-levels adjustable wire shelf.

DISPLAY BASKET (H x D x L)

860 x 450 x 900 mm

860 x 600 x 1000 mm

**DISPLAY
ACCESSORIES**

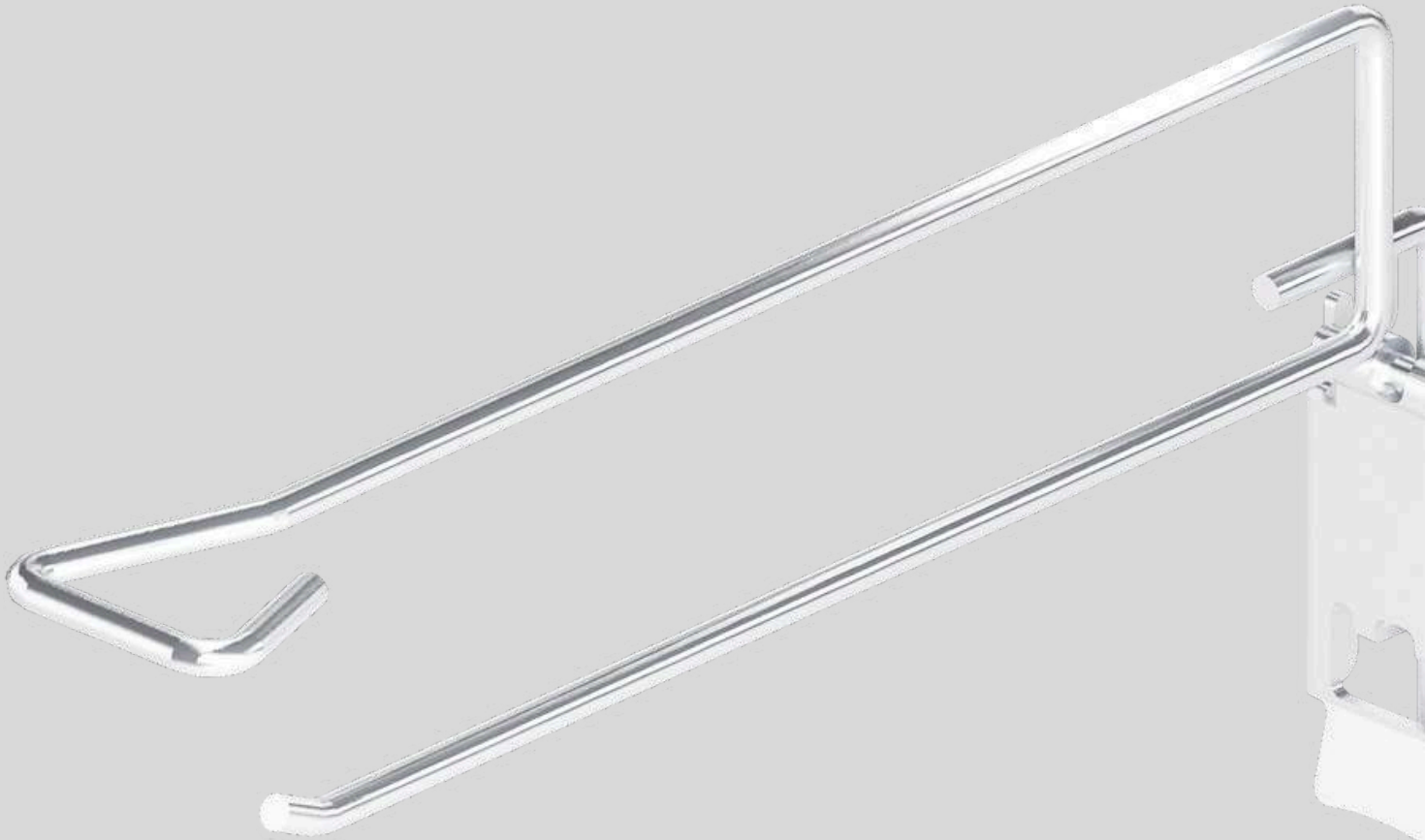

Accessory Solutions for Enhanced Functionality

A wide range of accessories designed for display units helps you organize and showcase products more efficiently and accessibly. Wire hooks, shelf dividers, baskets, label holders, and many more options optimize display areas by adapting to different product groups. With their modular structures, these accessories offer flexibility, allowing customization based on your store's needs while enhancing the customer experience. Combining functionality with aesthetics through durable and stylish designs, these accessories complete your display units!



Scan the QR code to access the technical catalog.

SHOPPING
TROLLEYS & BASKETS







Comfortable and Practical Shopping Experience

Shopping carts and baskets are designed to provide customers with a smooth and enjoyable shopping experience. Their ergonomic structure ensures easy handling, while lightweight yet durable materials offer long-lasting use. Available in various capacities and designs, they adapt to any store layout, making shopping more efficient. Enhance customer satisfaction with stylish and functional carrying solutions that set your store apart!

SV SERIES TROLLEYS



Plastic Part Color Options

	Standart	Renk	RAL 3020
	Optional		RAL 5015
	Optional		RAL 6018
	Optional		RAL 2004
	Optional		RAL 1023

Optional Travellator Castors



Optional Join Lock



The most popular model in the world with its solid chassis structure. It offers a solid and dynamic comfort with its oval profile chassis. With capacities ranging from 80 liters to 240 liters, a SV series shopping trolley is suitable for any store, in any size.

Capacity	80 lt.	100 lt.	125 lt.	150 lt.	180 lt.	210 lt.	240 lt.
Max Load	75 kg	90 kg	100 kg	130 kg	150 kg	160 kg	180 kg
Height (H)	950 mm	950 mm	1010 mm	1010 mm	1020 mm	1010 mm	1000 mm
Depth (D)	510 mm	510 mm	550 mm	570 mm	590 mm	570 mm	590 mm
Length (L)	850 mm	860 mm	900 mm	990 mm	1020 mm	1100 mm	1120 mm
Nesting Distance (R)	215 mm	215 mm	215 mm	240 mm	200 mm	250 mm	300 mm
40 HQ Container	600	600	540	550	570	436	364

ST SERIES TROLLEYS



Plastic Part Color Options

- Standart Color RAL 3020
- Optional RAL 5015
- Optional RAL 6018
- Optional RAL 2004
- Optional RAL 1023

Optional Travellator Castors



Optional Join Lock



Stylish and strong with its “all-wire” structure. You can use the upper basket more efficiently by moving the bottled or boxed products to the extra space at the bottom. Thus, you can have an increased turnover with this higher total capacity. Ranging from 80 to 240 liters, a ST series shopping trolley adds efficiency to every store.

Capacity	80 lt.	100 lt.	125 lt.	150 lt.	180 lt.	210 lt.	240 lt.
Max Load	75 kg	90 kg	100 kg	130 kg	150 kg	160 kg	180 kg
Height (H)	960 mm	960 mm	960 mm	1000 mm	1040 mm	1050 mm	1060 mm
Depth (D)	510 mm	510 mm	550 mm	580 mm	585 mm	570 mm	590 mm
Length(L)	800 mm	860 mm	890 mm	1020 mm	1030 mm	1100 mm	1120 mm
Nesting Distance (R)	190 mm	190 mm	225 mm	245 mm	245 mm	245 mm	230 mm
40 HQ Container	650	630	550	440	440	440	460

NOVA SHOPPING TROLLEY



Capacity	120 lt.
Max Load	98 kg
Height (H)	872 mm
Depth (D)	545 mm
Length(L)	987 mm
Nesting Distance (R)	165 mm
40 HQ Container	650
Truck	750

Plastic Part Color Options

- Standart Color RAL 3020
- Optional RAL 5015
- Optional RAL 6018
- Optional RAL 2004
- Optional RAL 1023

Optional Travellator Castors



Optional Join Lock



Turnover hunter" of small stores! Offering a volume of 115 liters and thanks to its deep basket design, NOVA has the smallest size compared to its counterparts. Designed for narrow aisles, NOVA is an ideal choice for 300 to 800 square meter stores. NOVA, which is the choice of the biggest discount chains in the world, offers consumers a comfortable shopping experience.

NOVA PC SHOPPING TROLLEY



Capacity	120 lt.
Max Load	98 kg
Height (H)	872 mm
Depth (D)	545 mm
Length(L)	987 mm
Nesting Distance (R)	165 mm
40 HQ Container	650
Truck	750

Plastic Part Color Options

- Standart Color RAL 3020
- Optional RAL 5015
- Optional RAL 6018
- Optional RAL 2004
- Optional RAL 1023

Optional Travellator Castors



Optional Join Lock







Turnover hunter" of small stores! Offering a volume of 115 liters and thanks to its deep basket design, NOVA has the smallest size compared to its counterparts. Designed for narrow aisles, NOVA is an ideal choice for 300 to 800 square meter stores. NOVA, which is the choice of the biggest discount chains in the world, offers consumers a comfortable shopping experience.

LOOP PLASTIC TROLLEYS



Plastic Part Color Options

-  Basket Color RAL 7021 RAL
-  Handle Color 3020 Pantone
-  Handle Color 123C Pantone
-  Handle Color 375C Pantone
-  Handle Color 287C Pantone

Optional
Travellator
Castors



LOOP, the new generation plastic shopping trolley, offers maximum volume in minimum dimensions; thanks to its ergonomic chassis structure. LOOP is the ideal choice for narrow aisles. With 3 different sizes, LOOP adds aesthetics and efficiency to your modern store concepts.





Capacity	100 lt.	160 lt.	200 lt.
Max Load	100 kg	150 kg	190 kg
Height (H)	1012 mm	1107 mm	1081 mm
Depth (D)	567 mm	597 mm	587 mm
Length(L)	587 mm	847 mm	1050 mm
Nesting Distance (R)	125 mm	225 mm	215 mm
40 HQ Container (standart wheels)	736	424	408
Truck (standart wheels)	832	480	472

POLYCARD PLASTIC TROLLEYS



Capacity	100 lt.	130 lt.	175 lt.	220 lt.	240 lt.
Max Load	80 kg	96 kg	160 kg	175 kg	220 kg
Height(H)	962 mm	979 mm	1024 mm	1057 mm	1173 mm
Depth (D)	580 mm	580 mm	582 mm	585 mm	596 mm
Length (L)	830 mm	945 mm	1067 mm	1082 mm	1073 mm
Nesting Distance (R)	160 mm	180 mm	210 mm	250 mm	280 mm
10 Trolleys Length	2270	2565	2957	3332	3332
40 HQ Container	700	620	424	352	234

Plastic Part Color Options

	Basket Color	RAL 7021 RAL
	Handle Color	3020 Pantone
	Handle Color	123C Pantone
	Handle Color	375C Pantone
	Handle Color	287C Pantone

Optional Travellator Castors



- 100% recyclable
- UV protection
- Custom logo printing for your brand
- Maximum safety for children with its double safety special baby set design.

JR KIDS TROLLEY



Capacity	100 lt.
Max Load	80 kg
Height(H)	1030 mm
Depth(D)	580 mm
Length(L)	1515 mm
40 HC Container	75

JR helps kids enjoy shopping while offering a large capacity with its 100 liters basket. The additional central caster provide a comfortable and safe environment for these little shoppers. With its seat and steering wheel, JR gives kids the real-feel of a car and keeps them safe with built-in seat belt.



Minimum Order : 30 Pcs

SWEET KIDS TROLLEY



Capacity	20 lt.
Height(H)	720 mm
Depth(D)	375 mm
BHeight With Pole	1470 mm
Ads Area	50x130 mm
Flag	Optional

Plastic Part Color Options

- Standart Color RAL 3020
- Optional RAL 5015

SWEET is designed for the shopping pleasure of kids along with their parents. With its 20 liter capacity plastic baskets in two different colors, the cheerful-looking SWEET will make children love shopping.



Minimum Order : 50 Pcs

EASY-B BABY TROLLEY



Height (H)	1020 mm
Depth(D)	630 mm
Length(L)	1180 mm
Upper Basket	25 lt.
Hand Basket Volume	22 lt.
Seating Material	PE
Casters	100 mm TPE

Color Options

 RAL 7024

Easily keep your eyes on your child with Easy-B Shopping Trolley. Providing a safe seat with a seat belt, Easy-B is designed for infants and kids between the ages of 6 months to 3 years.

Easy-B offers a total volume of 47 liters, with a 25-liter upper basket and a lower space for a 22/28 liters hand basket.



Minimum Order : 30 Pcs

EASY-B TWIN BABY TROLLEY



Height (H)	1020 mm
Depth(D)	630 mm
Long(L)	1060 mm
Upper Basket	22 lt.
Hand Basket Volume	22 lt.
Seating Materials	PE
Casters	100 mm TPE

Color Options

 RAL 7024

Does your customer have 2 kids or twins? With Easy-B Twin, you can ensure that they shop safely together with their kids. Easy-B Twin provides 2 individual safe and secure seats with seat belts for infants and kids



Minimum Order : 30 Pcs

B65 WHEELED BASKET



Basket Volume	65 lt.
Height(H)	925 mm
Depth (D)	387 mm
Length(L)	499 mm

Color Options

- RAL 7015
- RAL 3000
- RAL 1023
- RAL 6024
- RAL 5002
- RAL 2004

QTY Pallet :

72 pcs

BLACK ROLL WHEELED BASKET



	BR65
Height(H)	875 mm
Depth (D)	390 mm
Length(L)	540 mm
Basket Volume	65 lt.
Nesting Distance	82 mm

Basket

- 02235

Band Color Options

- 02235
- 07235
- 03235

QTY Pallet:

72 pcs

SHOP&ROLL 65 WHEELED BASKET



Basket Volume	65 lt.
Height (H)	875 mm
Depth(D)	390 mm
Length (L)	540 mm
Nesting Distance	82 mm

Basket Color Options

- 02235
- 07235
- 03235

QTY Pallet: 72 pcs

BLACK ROLL 55 WHEELED BASKET



Basket Volume	55 lt.
Height (H)	405 mm
Depth (D)	390 mm
Length (L)	590 mm
Nesting Distance	85 mm

Basket Color

- 02235

Band Color Options

- 02235
- 07235
- 03235

QTY Pallet: 80 pcs

BLACK ROLL 80 WHEELED BASKET



Basket Volume	80 lt.
Height (H)	532 mm
DDepth (D)	410 mm
Length (L)	590 mm
Nesting Distance	85 mm

Basket Color

- 02235

Band Color Options

- 02235
- 07235
- 03235

QTY Pallet: 72 pcs

VOLTA BASKET TROLLEY



Capacity	56 lt.
Max Load	80 kg
Height (H)	1100 mm
Depth (D)	600 mm
Length(L)	530 mm

Trolley Color

 RAL 7016

Basket Color Options

 RED

 GREEN

 BLUE

Discover our basket trolley, which is designed with the harmony of metal body and plastic and makes the shopping experience of the users practical with its high maneuverability in narrow aisles!



Used with 2 **VOLTA** Hand Baskets.

VOLTA TROLLEY



Capacity	40 lt.
Max Load	80 kg
Height (H)	1090 mm
Depth (D)	750 mm
Length (L)	555 mm

Trolley Color

 RAL 7016

 RAL 9005





A big solution for small-sized markets: Meet VOLTA, the user-friendly shopping marvel designed to maximize efficiency even in narrow aisles!

LOOP DOUBLE TROLLEY



Capacity	70 lt.
Nesting Distance	120 mm
Height (H)	1051 mm
Depth (D)	527 mm
Length(L)	647 mm

Plastic Part Color Options

	Basket Color	RAL 7021 RAL
	Handle Color	3020 Pantone
	Handle Color	123C Pantone
	Handle Color	375C Pantone
	Handle Color	287C Pantone

Small, compact shopping cart at two heights maximise the use of space. Ideal for narrow aisles. With the best castor wheels in the market, top quality and durability.

SNUPY BASKET TROLLEY



Height (H)	600 mm
Depth (D)	480 mm
Length (L)	985 mm
Upper Basket	60 lt.
Handle Basket Volume	2x28 lt.

Trolley Color

 RAL 7016

Basket Color Options

 RED

 GREEN

 BLUE

Discover the ergonomic and maneuverable basket trolley that provides 60 lt volume for narrow corridors!



Minimum Order : 20 Pcs

HANDLE BASKET 22 LT.



Basket Volume	22 lt.
Height (H)	230 mm
Depth (D)	300 mm
Length(L)	435 mm

Basket Color Options



Number of Box

Box : 20 Pcs

HANDLE BASKET 28 LT.



Basket Volume	28 lt.
Height (H)	260 mm
Depth (D)	335 mm
Length(L)	480 mm

Basket Color Options



Number of Box

Box : 20 Pcs

VOLTA HANDLE BASKET



Basket Volume	28 lt.
Height (H)	250 mm
Depth (D)	306 mm
Length (L)	520 mm

Basket Color Options



Number of Box

Box : 10 Pcs

WIRE HANDLE BASKET



Basket Volume	20 lt.
Height (H)	200 mm
Depth (D)	320 mm
Length(L)	450 mm

Basket Color



Band Color Options



GREAT HANDLE BASKET



Basket Volume	28 lt.
YHeight (H)	310 mm
Depth (D)	300 mm
Length(L)	475 mm

Basket Color Options

-  Red
-  Green
-  Blue

QTY Pallet:
200 pcs



BLACK ROLL 20 LT.



Basket Volume	20 lt.
Height (H)	215 mm
Depth (D)	310 mm
Length (L)	480 mm

Basket Color
 02235

Band Color Options

-  02235
-  07235
-  03235



QTY Pallet:
200 pcs

SOPHIE HANDLE BASKET



MODEL	SHP 15	SHP 6
Height(H)	285 mm	219 mm
Depth (D)	290 mm	196 mm
Length (L)	390 mm	292 mm
Basket Volume	15 lt.	6 lt.
Carrying Capacity	8 kg	5 kg
Per Pallet	224	512

Basket Color

-  Black
-  P. 563C
-  Transparent





Special colors can be made for orders of 1000 pieces or more.

DELUX HANDLE BASKET



Basket Volume	12 lt.
Height (H)	185 mm
Depth (D)	250 mm
Length(L)	385 mm

Basket Color

-  Black
-  White

QTY Pallet:
360 Pcs

K SERIES CARGO TROLLEYS



K5





K4 Mini/ Maxi

Model	K4-Mini	K4-Maxi / K5
Max Load	300 kg	450 kg
Height (H)	950 mm	950 mm
Depth (D)	610 mm	720 mm
Length (L)	1160 mm	1400 mm
Nesting Distance (R)	265 mm	265 mm

The high capacity K-series cargo trolleys is an ideal solution to carry products from the back-warehouse to the store. It has 2 different size options. The small version K4S is suitable for a warehouse/store with small aisles or to be loaded in an elevator. A K-series cargo trolley is also used as a shopping trolley in large square meter wholesale stores, offering a silent comfort with its custom made rubber wheels. Configured with 2 swivel front wheels and 2 fixed rear wheels. Occupies minimum space in the store, thanks to its nesting design.

Color Options

-  RAL 5010
-  RAL 7046
-  ZINC

D70 CARGO TROLLEY



Basket Volume	20 lt.
Max Load	200 kg
Height (H)	950 mm
Depth (D)	540 mm
Length (L)	870 mm
Nesting Distance (R)	285 mm

Color Options



Fast, flexible and agile, the D 70 provides a comfortable and high capacity transport; thanks to its nesting design and the rear wire basket. High maneuverability with four moving wheels and high loading capacity of 200 kg.

M SERIES CARGO TROLLEY



Model	M4-Mini	M4-Maxi
Max Load	200 kg	250 kg
Height (H)	890 mm	1050 mm
Depth (D)	530 mm	650 mm
Length (L)	700 mm	950 mm

Color Options



The best way to quickly transport boxed goods between the back-storage and the store is to use the M series cargo trolleys. With 2 alternative sizes, the M series cargo trolleys have 2 fixed and 2 swivel casters and a reversible handle which offers great ergonomics by giving the user 2 control options: pull or push. This removable handle also helps M series occupy minimum space in the warehouse when not in use.



+90 (224) 441 66 61

sova@sovaretail.com

Üçevler Mah. Ertuğrul Cad.
No:89A, Nilüfer, 16120
Bursa, Türkiye

SOVA